

LINCOLN HIGH SCHOOL

2024-2025 School Year

Program of Studies

Education is a partnership between parents, students, and the school. Parents are invited to actively participate in their student's educational program. We encourage all parents to contact us with any questions or concerns they may have relative to their student's status in school. The entire staff of Lincoln High School stands ready to help students and parents in the registration process.

Administration: Ronald Rasmussen- Principal,
Nicholas Sydorowicz, Steven Thayer, and Kelly Zywicki- Associate Principals

Lincoln High School's Student Services staff is available to provide special help and assistance.

Lincoln High School Student Services:

Phone: 715.424.6755

Stephanie Derringer (last names A-Da)

Jordan Brummond (last names De-I)

Lisa Banks (last names J-Mi)

Ann Felker (last names Mo-Sc)

Jenna Peterson (last names Se-Z)

Destiny Clark (Psychologist)

Aida Juarez (Psychologist)

Anthony Fannin (Virtual)

Registration For Classes: Course selection is a process students and parents should take seriously. Parents are asked to approve all student course selections and are encouraged to contact school personnel with any questions or concerns.

Students . . .

- . . . are reminded that decisions made in the registration process are important and not to be taken lightly.
- . . . should make their course selections carefully and discuss them with their parents, teachers, and counselor.
- . . . when registering for classes, choices should be based on their interests, needs, career aspirations, and graduation requirements.
- . . . are reminded that changes will not be made after **March 1st**.

Parents . . .

- . . . should encourage students to take full advantage of the investment all of us have made in education in Wisconsin Rapids.
- . . . must approve their student's registration requests.
- . . . are reminded that careful planning now will assure a productive and beneficial education in both the short and the long term.

We wish you an enjoyable and pleasant school year.

Motto

LHS/Rapids P.R.I.D.E--Personal Responsibility In Developing Excellence

Mission

To develop the skills and character to achieve success

VISION

Our Lincoln High School community is a source and pride of innovation. We will create an engaging, inspiring and challenging learning environment that encourages all students to achieve at their maximum potential by monitoring student learning and providing feedback.

We will provide students with opportunities to:

- evolve into respectful, responsible, and committed young adults,
- gain a vision of what careers and educational opportunities might be best for them,
- earn post-secondary credits while in high school,
- experience online and/or blended courses, and
- grow proficient in using a variety of technology.

BELIEFS

We believe--

- each person is unique.
- learning is an essential lifelong process.
- all students will learn.
- all students will be assured of a safe environment.
- all students will collaborate.
- all students will demonstrate responsibility.
- effective teaching and learning can be achieved in a variety of ways.
- co-curricular opportunities are a valuable component of a student's high school educational experience.
- students will integrate knowledge from all disciplines and experiences to solve real-world problems.
- developing critical thinking, problem-solving, and communication skills in students are critical to a student's success in school and afterward.

COLLECTIVE COMMITMENTS

We will--

- Bring enthusiasm to the classroom.
- Teach and model good values and positive behaviors.
- Create supportive relationships that foster dignity and respect.
- Celebrate the accomplishments of students and staff.
- Promote a safe atmosphere that is conducive to thinking, sharing, and learning.
- Be prepared and use class time well.
- Use data analysis as a means to drive change in our practices and to use research-based tools to guide needed practices.
- Improve by being reflective, seeking feedback and revising our work.
- Challenge ourselves.
- Collaborate with others to improve our work and understanding.

Table Of Contents

Registration Policies and Graduation Requirements.....	4-5
Attendance, Skyward, Reading Intervention, Math Essentials, English Learners.....	6
LEAP, River Cities H.S., Gifted & Talented, Early College Credit, Start College Now.....	7
Youth Apprenticeship, Career Clusters, Academic & Career Planning Center.....	8-11
Advanced Standing, Dual Credit, Concurrent Enrollment, Equivalency Credit.....	12-14
Advanced Placement, Preparation for Technical College, Apprenticeships, Universities, and Colleges.....	15-16
Agriculture.....	17-18
Art.....	19-23
Business Education, Computer Science and Marketing Education.....	24-30
English Language Arts.....	31-36
Family and Consumer Sciences.....	37-41
Health Education, Health Science	42-44
Mathematics.....	45-50
Music.....	51-53
Physical Education.....	54-56
Science.....	57-63
Social Studies.....	64-70
Special Education.....	71-75
Technology Education.....	76-83
World Languages, Global Scholar.....	84-85
NCAA.....	86-90
Co-Curricular Activities, Success Center Tutor Program, Pride Program.....	91-92
Schedule Pick up, Link Crew.....	93
Four Year Planning Chart.....	94

LINCOLN HIGH SCHOOL REGISTRATION POLICIES

When choosing courses, a student's career goals, learning style, and interests should be taken into consideration. Students are encouraged to take full advantage of the many opportunities available at Lincoln High School.

Students should **SELECT COURSES CAREFULLY!** Many administrative decisions are made based on course registration, budget, class size, and teacher assignments.

1. All students grades 9-12 must register for a minimum of 6.0 credits.
2. No class offering is guaranteed. Because of limited registration enrollments and the needed approval by the Board of Education for all classes, some classes may eventually be cancelled. Students will have the opportunity to provide alternate classes to be used in this situation.
3. Students are encouraged to meet with their counselor to review their selections.
4. Students can choose which term they would like a study hall, however this request is not guaranteed. Study hall placement may be determined by course availability.

Once schedules are created:

1. Students must be enrolled in 2 credits per trimester.
2. Students should be enrolled in a maximum of 7.5 credits during a traditional school year unless an extenuating circumstance is approved by administration.
3. If your schedule contains two study halls in one term and none in the others, please see your counselor **within the first 3 days** of the term to make a change.
4. If you have a two term gap in math or World Language, see your counselor within the first **3 days** of the term to attempt a schedule change.
5. Within the first **3 days** of each term, students may add a class if an opening exists during a period scheduled for a study hall.
6. Schedule changes will be considered only in specific circumstances as defined by the schedule change process. The final appeal **deadline is the 3rd day** of school after the start of classes. Complete a Schedule Correction Form in Student Services and see if your request would qualify.

Withdrawal/Failure Policy

A "W" grade indicates that a student has dropped a class after the start of the term. A class may only be dropped/changed based on the schedule change policy.

1. Students will receive a "W" grade on their transcripts if a class is dropped/changed between **days 4 and 7** of a term.
2. After **day 7** of a term, students will receive an "F" grade on their transcripts unless there are extenuating circumstances determined by administration.

Repeating a Failed or Passed Class

A student may repeat a class he/she has previously failed or earned a D+, D, or D-. The original grade will appear on the student's transcript, however the most recent grade will be the grade calculated into the student's cumulative GPA.

Course Fees

Several of our courses have additional fees. If you have concerns about being able to take a course because of the associated fees, please see your school counselor.

LINCOLN HIGH SCHOOL GRADUATION REQUIREMENTS

All students must complete a minimum of **24.0** credits, grades 9 through 12, to be certified for graduation. Credits are based on a time-in-class standard or the traditional Carnegie Unit of determination. This is a list of the minimum credits which must be earned in designated subject areas grades 9 through 12.

English.....4.0 Credits	Physical Education.....1.5 Credits
Social Studies.....3.0 Credits	Financial Literacy.....0.5 Credit
Mathematics.....3.0 Credits	Health.....0.5 Credit
Science.....3.0 Credits	IT Fundamentals I.....0.5 Credit
Electives make up the remaining 8.0 Credits	

**Specific courses within the academic areas listed above may be required for graduation.
See each department's pages for their requirements.**

Students must pass the Wisconsin State Civics Test as part of their graduation requirements.
(This is usually taken during the student's American Government class.)

****Financial Literacy Credit can be satisfied with any of the following courses:**

- | | |
|---|------------------------------|
| *Personal Finance - No. 506 | *Financial Algebra - No. 421 |
| *Accelerated Financial Algebra- No. 422 | *On Your Own - No. 939 |
| *Principles of Economics - No. 222 | *AP Macroeconomics - No.233. |
| *AP Microeconomics- No. 234 | |

***PLEASE NOTE: All course fees must be paid in order for a student to walk at graduation.**

Grade Point Values

For All Classes

A	4.00
A-	3.67
B+	3.33
B	3.00
B-	2.67
C+	2.33
C	2.00
C-	1.67
D+	1.33
D	1.00
D-	0.67

Remember This About Graduation...

All graduation requirements and student obligations (fines, detentions, etc.) must be met before a student may receive a diploma or participate in the graduation ceremony. Appeals related to requirements, graduation, or participation in the graduation ceremony are subject to review by the high school principal. Students who plan on participating in the graduation ceremony must attend the graduation practice as scheduled.

IT IS THE STUDENT'S RESPONSIBILITY TO MAKE SURE THAT ALL GRADUATION REQUIREMENTS ARE MET.

ATTENDANCE, SKYWARD, INTERVENTIONS, ENGLISH LEARNERS

Attendance In School Is Extremely Important

State Statute 118.15 indicates the following: “any person having under his or her control a child who is between the ages of six and 18 must cause the child to attend school regularly until the end of the school term, quarter, or semester of the school year in which the child turns 18 years of age.”

Attendance and completion of high school is extremely important. Your attendance becomes a part of your PERMANENT record. This information will be sent out every time your transcripts are sent to colleges or employers. Make your school attendance a top priority in your life! Excellent school attendance gives you the greatest chance for academic success in the classroom. High school attendance is also one of the most important criteria employers use when hiring employees.

When a student has accumulated 10 absences in a school year, whether excused or unexcused, they are considered to be excessively absent. The state allows parents to excuse their child up to 10 days in a given school year. After the 10 days, the student will be required to provide documentation from a doctor or other health care professional, a probation officer or social worker, police officer or judge in order to be excused.

Skyward Family Access

Family Access is a web-based service that allows parents and authorized family of secondary students to view attendance records, schedule, assignments, report cards, and progress reports. The first thing to do is e-mail famaccess@wrps.org. Include your name, address, telephone number, student(s) name(s), indicate which school your student(s) attend, and your e-mail address. You will receive a confirmation e-mail from us with your login and password. After you receive the e-mail go to www.wrps.org, click on *For Parents* and choose *Family Access*. For further instructions or information, see your school office.

Online Verification- Please continue to update your family's information in Family Access at the beginning of each year and throughout the year as any changes in your address, telephone number, medical information or emergency contact information occur. You can complete your online verification in the Family Access screen under Online Enrollment Verification. For further instructions or information, see your school office.

Reading Intervention

Lincoln High School offers learning opportunities for students whose reading is below or above the grade-level benchmark. Students are selected for intervention or enrichment based on their achievement data and then matched to the appropriate instruction according to individual needs. Progress is monitored and instruction adjusted to ensure students are responding to the intervention/enrichment and progressing toward the academic goal. Students taking this course are awarded a pass/fail grade.

Math Essentials

This course is designed as a second math class for elective credit for those students needing extra remediation and support in their current math course. Students taking this course are awarded a pass/fail grade. An individual plan is set by the instructor as per each student's needs.

English Learners

This course is intended to give students assistance with homework in all subjects. Students are expected to bring work every day. A teacher and/or instructional aides will be available to read and explain content to students. Tests may also be taken and read orally to students through this course. Students will also have multiple learning resources available to them through this course, including computers and graphing calculators.

Students must be enrolled in the EL program to register for Study Lab.

LEAP, RIVER CITIES HIGH SCHOOL, GIFTED & TALENTED, EARLY COLLEGE CREDIT/START COLLEGE NOW

Lincoln Educational Alternative Program (LEAP)

LEAP, Lincoln's Educational Alternative Program, has a unique function within Lincoln High School. The purpose of LEAP is to help students who are experiencing difficulties in the regular academic setting. The curriculum attempts to deal with the reasons or academic barriers students have so that they will have a successful academic experience. Goals are to increase academic success and self-esteem while providing for continued academic support. Freshman and Sophomore students take 'Lincoln Launch' for their monitoring and support, while Juniors and Seniors take 'Lincoln Lift' for their monitoring and support. Courses are 1/2 credit per term, an elective, and are graded Pass/Fail. As a student enrollment is based on criterion as denoted from a screening tool(s), student exit from LEAP will be based on grades, attendance, discipline record, and teacher, counselor, parent/guardian approval, as documented and verified through the exit process. A LEAP department team meeting and discussion are part of the exit process.

River Cities High School

River Cities High School is an application-based alternative high school within the Wisconsin Rapids Public School District for credit-deficient students. For more information visit, <http://www.wrps.org/schools/rivercities/rchshandbook.cfm>.

Gifted and Talented Opportunities

- Appropriate modification of content, process, environment and product.
- Ongoing lessons and activities within the regular classroom which provide enrichment opportunities and challenges for students.
- Classroom opportunities which emphasize critical thinking, creative thinking, and problem solving.
- Flexible pacing, curriculum compacting, acceleration, concurrent course enrollment, small group pull-outs, independent projects and/or mentorships for students with demonstrated strengths, talents, and interests.
- Curricular choices, options and electives for students desiring more intensive study and work including advanced placement classes or acceleration.
- Counseling and support group services to ensure a supportive and challenging school experience.
- Individual programming options for exceptionally creative and talented students.
- Lincoln High School provides a variety of school enrichment activities, clubs, and organizations.
- Access to the WRPS Gifted & Talented Educational Services Facilitator/Differentiated Educational Plan.

What to do?

If you feel that your child or student has a specific strength, a unique talent, or a sustained interest:

- First bring up the matter with the classroom teacher and share your thoughts and feelings.
- If you still have questions or need further information, please contact the GATES Coordinator.

Early College Credit (ECCP) and Start College Now (SCN)

Early College Credit Program (ECCP) and **Start College Now (SCN)** are state programs that support 11th and 12th grade high school students requesting to take non-comparable courses at the university or technical college level.

Wisconsin State Statute 38.12 (14) allows high school students to take classes at a technical college through Start College Now. If students are approved by their school district to take courses through SCN, school districts pay for the technical college course fees. Students will earn credit for the technical college courses from both the high school and the technical college.

Wisconsin State Statute 118.55) allows Wisconsin public and private high school students to take one or more courses at an institution of higher education for high school and/or college credit. Under ECCP, the cost of tuition for approved courses is shared among the school district or private school, the state, and in some cases the students.

Application deadlines for SCN and ECCP are March 1st for fall courses and October 1st for spring courses. See your school counselor for more information on either program.

YOUTH APPRENTICESHIP PROGRAM

Youth Apprenticeship Program

Course: 515

Credit: .5, 1.0 or 1.5

Grades: 11, 12

Youth Apprenticeship is a unique opportunity for juniors and/or seniors to start preparing for a career while in high school. Students are simultaneously enrolled in academic classes to meet high school graduation requirements, in a youth apprenticeship related instruction class, and are employed by a participating employer under the supervision of a skilled mentor.

Key Elements:

- Exposure to multiple aspects of the industry
- Industry-developed skill standards
- Skilled mentors assigned to train the students
- Paid on-the-job work experience and high school credit
- Related classroom instruction concurrent with work-based learning
- Earn an industry recognized completion certificate

Programs Offered at Lincoln High School:

- Agriculture, Food and Natural Resources
- Architecture and Construction
- Arts, AV Technology & Communication
- Business Administration (NEW)
- Child Care Teacher (Local with DPI Certification)
- Education (NEW)
- Finance
- Health Science
- Hospitality & Tourism
- Information Technology
- Manufacturing
- Marketing
- STEM (Science, Technology, Engineering and Math)
- Transportation, Distribution and Logistics (Auto Technician)







How do students get involved in this program?

Interested students must apply through their school counselor and/or career & technical education (CTE) coordinator. Selection based on career interest, skills, employability, attitude, attendance, credits, grades and recommendations. This program is competitive and subject to business and industry availability.

16 CAREER CLUSTERS

	<p>The production, processing, marketing, distribution, financing and development of agricultural commodities and resources including food, fiber, wood products, natural resources, horticulture, and other plant and animal products/resources.</p>
	<p>Careers in designing, planning, managing, building and maintaining the built environment.</p>
	<p>Designing, producing, exhibiting, performing, writing, and publishing multimedia content, including visual and performing arts and design, journalism, and entertainment.</p>
	<p>Business Management and Administration careers encompass planning, organizing, directing, and evaluating business functions essential to efficient and productive business operations. Business Management and Administration career opportunities are available in every sector of the economy.</p>
	<p>Planning, managing, and providing education and training services, and related learning support services.</p>
	<p>Planning services for financial and investment planning, banking, insurance, and business financial management.</p>
	<p>Executing governmental functions to include Governance; National Security; Foreign Services; Planning; Revenue and Taxation; Regulation; and Management and Administration at the local, state, and federal levels.</p>
	<p>Planning, managing, and providing therapeutic services, diagnostic services, health informatics, support services, and biotechnology research and development.</p>
	<p>Hospitality & Tourism encompasses the management, marketing and operations of restaurants and other food services, lodging, attractions, recreation events and travel related services.</p>
	<p>Preparing individuals for employment in career pathways that relate to families and human needs.</p>

16 CAREER CLUSTERS

	<p>Building Linkages in IT Occupations Framework: For Entry Level, Technical, and Professional Careers Related to the Design, Development, Support and Management of Hardware, Software, Multimedia, and System Integration Services.</p>
	<p>Planning, managing, and providing legal, public safety, protective services and homeland security, including professional and technical support services.</p>
	<p>Planning, managing, and performing the processing of materials into intermediate or final products and related professional and technical support activities such as production planning and control, maintenance and manufacturing/process engineering.</p>
	<p>Planning, managing, and performing marketing activities to reach organizational objectives.</p>
	<p>Planning, managing, and providing scientific research and professional and technical services (e.g., physical science, social science, engineering) including laboratory and testing services, and research and development services.</p>
	<p>Planning, management, and movement of people, materials, and goods by road, pipeline, air, rail and water and related professional and technical support services such as transportation infrastructure planning and management, logistics services, mobile equipment and facility maintenance.</p>

Career Clusters

The LHS Program of Studies incorporates the National 16 Career Clusters into its departments. Throughout this publication you will see icons relating to each of the 16 Career Clusters that have been identified: (See logos and descriptions on this page.)

Almost all career possibilities can be found within the clusters. Students at Lincoln High School are fortunate to have the opportunity to take coursework relevant to all 16 Career Clusters. Communicating career and educational goals to your school counselor, and working in Xello through the Academic and Career Planning process can aid students in choosing relevant and applied coursework designed to meet their individual educational and career goals.

My top three Career Clusters of interest are:

1. _____
2. _____
3. _____

ACADEMIC AND CAREER PLANNING CENTER

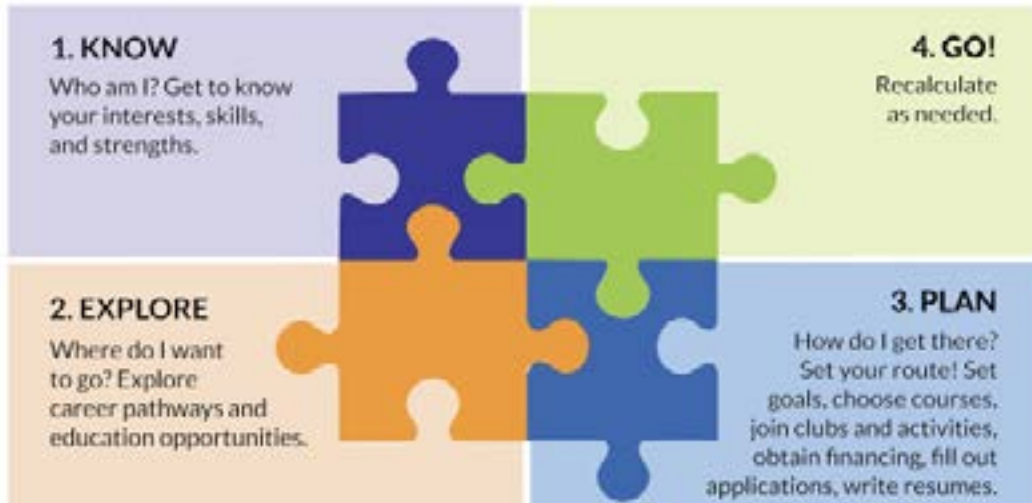

LINCOLN'S ACP CENTER

The ACP (Academic & Career Planning) Center is a working space designed specifically to support students with their academic and career planning needs. ACP is a student-driven, adult-supported process. Students create and cultivate their own unique and information-based visions for post-secondary success, obtained through self-exploration, career exploration and the development of career management skills. Open Monday-Friday, 7:15 am - 3:15 pm, all students are encouraged to stop in and explore the numerous resources available throughout their high school career.

The ACP Center coordinates school sponsored fall and spring college campus field trips, ASVAB testing, senior financial literacy simulation, job shadowing, mock interviews, job board offerings, sophomore higher education showcase, "Apply for Free" events, FAFSA fill-in nights, spring Teen Job Fair, the Academic and Career Planning curriculum and assists with the coordination of the annual LHS Career Discovery Day.

Each year, students will utilize the software program, Xello, to explore options through assessments and lessons. It also houses their ACP affiliated work which eventually will become their own personal career exploration portfolio. This is meant to be a gradual process that builds from one year to the next, supporting the development of each student. Student goals and plans are expected to change as their personal, school, volunteer, work and overall life experiences expand.

Stay connected and up to date on the latest happenings by following the ACP Center on social media: Facebook @LHSACPCenter, Twitter @LHS_ACP and Instagram @LHS_ACPCenter

LINCOLN HIGH SCHOOL'S VOLUNTEER PROGRAM

The Lincoln High School Volunteer Program is available for all students, grades 9-12, on a voluntary basis. No academic credit is given for participation. Students who submit 100 or more volunteer hours by the spring of their Senior year will receive special recognition at graduation, which includes a denotation on the graduation program, a sticker on their diploma and their name displayed on the tv's around the school.

Volunteering is an excellent way to help others in our community, meet new people, develop and refine skills necessary for the future workforce, try out new things and have a better understanding of our community.

Details of how and where students should submit their volunteer hours, as well as viewing current volunteer opportunities can be found by visiting: <https://www.wrps.org/schools/lincoln/academics/volunteerprogram.cfm>.

ADVANCED STANDING & DUAL CREDIT AGREEMENTS

Dual Credit (DC)

Dual credit courses are an agreement between Lincoln High School and Mid-State Technical College. All students have the opportunity to participate and receive both high school credit and technical college credit in specific courses. Students will have the option to enroll in dual credit at the start of their Lincoln High course. Upon successful completion of the dual credit course, students that opted in will receive an official Mid-State transcript. Students must decide at the beginning of their Lincoln High School course if they wish to sign up for dual credit; students have up until 80% of the class meetings have occurred to withdraw from the dual credit option. No fee is required to earn dual credit. See page 12-13 for agreements.

Advanced Standing (AS)

The Wisconsin Technical Colleges Advanced Standing Program (AS) enables high school students to pursue Technical College credits while taking high school classes. Agreements between Lincoln High School and Wisconsin Technical Colleges make it easy to start earning college credit while in high school. Here's how it works:

- Once you complete specific high school courses and demonstrate the class competencies by earning an “A” or “B”, you will be eligible to earn Advanced Standing credit; no fee is required.
- Lincoln High School instructors, counselors, and administration are all involved in the Certificate of Advanced Standing (AS) process.
- The Advanced Standing course credit can be used to fulfill program course requirements at Mid-State. Advanced Standing credits will not be included in calculating your Mid-State grade point average and will **NOT** transfer to a four-year university system.

Lincoln High School currently offers a variety of Advanced Standing and Dual Credit agreements with Mid-State Technical College. See page 12-13 for agreements.

BETWEEN WISCONSIN RAPIDS LINCOLN HIGH SCHOOL AND MID-STATE TECHNICAL COLLEGE

Catalog #	Credits	MSTC Course	LHS Course
AGRIBUSINESS DIVISION			
10001111	2	Introduction to Horticulture	Introduction to Horticulture (Dual Credit)
10001199	3	Intro to Fisheries, Forestry and Wildlife Resources	Intro to Fisheries, Forestry and Wildlife Management (Dual Credit)
10001148	3	People, Resources, and Sustainability	Natural Resources (Dual Credit)
BUSINESS DIVISION			
10101111	4	Accounting I	Accounting II (Dual Credit)
10106106	3	Quality Customer Service	Business Communications (Dual Credit)
10104107	3	Social Media Marketing	Sports, Event, & Social Media Marketing (Dual Credit)
10104102	3	Marketing Principles	Marketing Principles (Dual Credit)
10102101	3	Intro to Business	Starting a Small Business (Dual Credit)
10103106	3	Microsoft Office- Introduction	IT Fundamentals II (Dual Credit)
10154102	3	Hardware Essentials	A+ Computer Maintenance & Repair (Dual Credit)
10154110	3	Desktop Management	Student Help Desk (Dual Credit)

Agreements are subject to change at any time. Revised 11/2023

ADVANCED STANDING & DUAL CREDIT AGREEMENTS

Catalog #	Credits	MSTC Course	LHS Course
GENERAL EDUCATION DIVISION			
10804118	4	Intermediate Algebra with Applications	Intermediate Algebra (Dual Credit)
31804305	2	Applied Mathematics	Applied Math for the Trades (Dual Credit)
10809196	3	Introduction to Sociology	Sociology (Dual Credit)
10809172	3	Introduction to Diversity Studies	Introduction to Diversity Studies (Dual Credit)
20803211	3	U.S. History to 1877	AP United States History A (Dual Credit)
20803212	3	U.S. History 1877 to Present	AP United States History B (Dual Credit)
10806154	4	General Physics I	General Physics 1 (Dual Credit)
10806134	4	General Chemistry	AP Chemistry (AS)
10801196	3	Oral/Interpersonal Communication	One of the following: Speech Communications I; Speech Communications II (AS)
10801195	3	English Composition 1*	One of the following: English III; AP English Literature & Composition (AS)
SERVICE & HEALTH DIVISION			
10307151	3	Infant and Toddler Development	Infant and Toddler (Dual Credit)
10307148	3	Foundations of Early Childhood Education	Assistant Child Care Teacher (Dual Credit)
10307179	3	Child Development	Child Development (Dual Credit)
10546101	3	Nutrition for Healthy Living	Nutrition for Healthy Living (Dual Credit)
10501101	3	Medical Terminology	Medical Terminology (Dual Credit)
10546101	3	ECE: Health, Safety, and Nutrition	Health, Safety, and Nutrition (Dual Credit)
10546110	3	Mental Wellness and Stress Management	Mental Wellness and Stress Management (Dual Credit)
10316112	1	Sanitation for Foodservice Operations	Professional Cooking II (Dual Credit)
TECHNICAL & INDUSTRIAL DIVISION			
10601140	2	Electricity for the Construction Trades	Advanced Electricity (Dual Credit)
10623114	1	Inventor	Computer Aided Drawing and Design (Dual Credit)
31442320	1	Welding Foundations 1	Welding Technology 1 (Dual Credit)
10442118	1	Introduction to Welding Fundamentals 2	Welding Technology II (Dual Credit)
32420326	2	Introduction to Turning Machines	Manufacturing (Dual Credit)
105482107	2	Construction Fundamentals	Building Construction (Dual Credit)

*Advanced Standing is contingent upon the student earning a B or better grade in the corresponding high school courses.

*Oral/Interpersonal Communication-summer school speech **does not** meet requirements.

Agreements are subject to change at any time. Revised 11/2023

CONCURRENT ENROLLMENT & EQUIVALENCY OPTIONS



Concurrent Enrollment

Lincoln High School is pleased to be partnering with UWSP to offer concurrent enrollment course options. Successful completion of concurrent enrollment courses will result in students earning Lincoln High School credit while at the same time earning college credit on a UWSP transcript. UWSP courses offered through LHS are guaranteed to be transferable to any of the UW four-year college campuses. In addition, UWSP courses may transfer to any other higher education institution that typically accepts University of Wisconsin credits. UWSP concurrent enrollment courses are challenging, college level courses taught in high school. The benefits of taking UWSP courses in high school are numerous: students save money, students save time, students are better prepared for college, and students have the option of taking the class for high school credit only or for a combination of high school and college credit. On the other hand, students who struggle could possibly start college on academic probation.

Any junior or senior may take UWSP concurrent enrollment courses for high school credit. If a student would like to receive UWSP transcripted, college credit for the class, s/he must complete the following steps:

1. Register for the course at LHS.
2. Attend the informational meeting and enroll in LHS Canvas course.
3. Complete the concurrent enrollment confirmation form.
4. Complete the UWSP application and meet the required prerequisites.
5. Pay UWSP tuition rate for concurrent enrollment, which has been approximately half the cost of a typical UWSP course. Rates for the 23-24 school year were \$99/credit. Most of our UWSP classes are 3-5 credits so the cost ranges were \$297-\$495 per course.
6. Successfully complete the concurrent enrollment course.

Keep in mind that the cost of the class and transcripts are the responsibility of the student/parent.

LHS offers the following concurrent enrollment classes:

- College English 101 (3 credit course)
- College English 202 (3 credit course)
- Physics 101 (5 credit course)
- History 102 (3 credit course)

For up to date information about whether a concurrent enrollment course will transfer to the university of your choice please contact an admission counselor at that university and/or use the website: Transferology: <https://www.transferology.com/index.htm>

Equivalency Credit

The Wisconsin Department of Public Instruction (DPI) Equivalent Graduation Policy (PI 18.02) provides school districts the opportunity to expand options available to students to meet high school graduation requirements through “equivalent courses.” High School equivalent courses are those that have been determined to meet specific criteria, specifically courses which contain the time allotment and substantially the same objectives to develop the knowledge, concepts, and skills of the course for which an equivalent credit is proposed. Lincoln High School currently has five DPI approved equivalent courses.

Course Title	Academic Department	Credit Earned	Equivalency Earned In:
Large Animal Industry Science	Agriculture	0.5 Credit	Science
Small Animal Vet Science	Agriculture	0.5 Credit	Science
Principles of Engineering	Technology Education	1.0 Credit	Science
Food Science	Family & Consumer Science	0.5 Credit	Science
Business Communications	Business Education	0.5 Credit	English
Digital Electronics	Technology Education	1.0 Credit	Math

ADVANCED PLACEMENT (AP)



The College Board's Advanced Placement Program (AP) enables students to pursue college-level studies while still in high school. Based on their performance on rigorous AP Examinations, students can earn college credit, advanced placement, or both for college. Students who intend to apply for college admission and are willing to accept the challenge of a rigorous academic curriculum should strongly consider enrolling in at least one AP course during their sophomore, junior or senior year.

AP Exams represent the culmination of AP courses and are thus an integral part of the program. As a result, Lincoln High School fosters the expectation that students who enroll in an AP course will go on to take the corresponding AP Exam. Because the College Board is committed to providing access to AP Exams to all students, it does not require students to take an AP course prior to taking an AP Exam. However, students are highly encouraged to take a formal AP course at Lincoln High School before completing the corresponding AP exam. There will be a fee for each exam. This fee is determined by the college board.

AP Scholar Award

The AP Program offers several AP Scholar Awards to recognize high school students who have demonstrated college-level achievement through AP courses and exams. Although there is no monetary award, in addition to receiving an award certificate, this achievement is acknowledged on any AP score report that is sent to college in the following fall.

AP Scholar – Granted to students who receive scores of 3 or higher on three or more AP Exams.

AP Scholar with Honor – Granted to students who receive an average score of at least 3.25 on all AP Exams taken, **and** scores of 3 or higher on four or more of these exams.

AP Scholar with Distinction – Granted to students who receive an average score of at least 3.5 on all AP Exams taken, **and** scores of 3 or higher on five or more of these exams.

State AP Scholar – Granted to the one male and one female student in each U.S. state and the District of Columbia with scores of 3 or higher on the greatest number of AP Exams, **and then** the highest average score (at least 3.5) on all AP Exams taken.

AP/PLTW Scholar- If you complete three courses in a pathway — one AP course; one PLTW course; and a third course, either AP or PLTW — and earn a score of 3 or higher on the AP Exam(s) and a score of Proficient or higher on the PLTW End of Course (EoC) assessment(s), you've earned the AP + PLTW student recognition for that pathway.

L H S A P C O U R S E S	DEPT/SUBJECT	9th GRADE	10 TH GRADE	11 TH GRADE	12 TH GRADE
	Social Studies				
	Human Geography	X			
	US History		X		
	Psychology			X	X
	Government & Politics			X	
	Macroeconomics			X	X
	Microeconomics			X	X
	English				
	English Literature			X	X
	Math				
	Statistics			X	X
	Pre-Calculus			X	X
	Calculus A/B or B/C			X	X
	Science				
	Environmental			X	X
	Chemistry			X	X
	Art				
	Art History		X	X	X
	Music				
Music Theory		X	X	X	

EDUCATIONAL OPTIONS FOR LIFE AFTER HIGH SCHOOL

Preparation For Technical College/Apprenticeship

Subject	Years	Courses
English	4	Reading, Writing
Mathematics	2-3	Algebra, Geometry, Algebra 2 and beyond *Some programs may require additional courses.
Science	2	Some programs require specific categories of science; for example, Health Science majors, 1 credit of chemistry and biology
Social Studies	3	Human Geography or AP Human Geography; American History, America's Voice or AP US History; and one year of other social studies.
Critical Skills		Career and Technical education courses throughout high school.
Related Experiences		Extracurricular activities, including community service and volunteering throughout high school.
If you have any questions about Wisconsin's Technical Colleges, see your counselor or visit this web site: Wistechcolleges.org .		

Preparation For University/College

Entrance recommendations for students are printed below (see chart). These are GENERAL RECOMMENDATIONS for high school students who might want to go on to college. Additional preparation should be made for specific programs. The Student Services department can help you discover which extra courses might be helpful if you know which career area you wish to pursue or which college or university you hope to attend. For some universities the following are only minimum requirements.

Subject	Years	Courses
English	4	Accepted English courses stress an understanding of composition, literature and rhetoric. Significant practice in reading, writing and speaking is expected in composition and rhetoric. Several campuses require that at least 3 of the 4 credits in English include composition and literature.
Mathematics	3	One year in Algebra, Geometry, Algebra 2 and beyond *Some Schools require 4 years
Science	3	Suggested: courses in biology, chemistry, and physics
Social Studies	3	For up to date information please contact an admissions counselor at the campus you are interested in or check the college's website.
World Languages	Varies	Each campus has variations in college preparatory credit requirements for World Language. For up to date information please contact an admissions counselor at the campus you are interested in or check the college's website.
Additional Critical Skills & Experiences		Computer skills, visual & performing arts, other academic or career and technical electives throughout high school. Minnesota system schools recommends 1 credit of Fine Arts.
Recommended Related Experiences		As many extracurricular activities as possible including community service and volunteering throughout high school.

If you have any questions about the requirements of the University of Wisconsin system or a specific UW campus, you are encouraged to call this toll free number: 1-800-442-6459, or see your counselor or visit this web site: uwhelp.wisconsin.edu. For information on Wisconsin's Private Colleges and Universities call toll free 1-800-4-DEGREE or visit this web site: wisconsinprivatecolleges.org.

AGRICULTURE EDUCATION



Courses Required For Graduation From This Department: None

FFA is a Career and Technical Organization (CTSO) open to all students and provides opportunities in leadership development, travel, work experience, and employment opportunities to students enrolled in agriculture classes. FFA activities and award programs complement instruction in Agriculture Education by giving students practical experience in the application of agricultural skills and knowledge gained in class. All agriculture students are encouraged to participate in FFA activities throughout the course of the calendar year.

INTRO TO AGRISCIENCE

Course: 780
Credit: .5
Grade: 9, 10, 11, 12
Prerequisite: None
Fee: \$5.00

Interested in projects and experiments? Intro. to Agriscience is the course for you! Study topics in agriculture including agriculture history, agriculture technology and significant crops in the USA. Biotechnology, aquaculture, and composting will also be infused in the curriculum, with hands on practice in the school's greenhouse.

LARGE ANIMAL INDUSTRY SCIENCE

Course: 791
Credit: .5
Grade: 9, 10, 11, 12
Prerequisite: None
Fee: \$5.00

Explore the large animal industry! This course will focus units on the large animal industry including the beef and dairy cattle, swine, poultry, equine, and sheep. Throughout each unit students will learn about the following items: breeds, anatomy, feeding and management practices, products, housing, equipment, diseases and parasites. This course is designed to incorporate real life simulations, labs, and activities that will allow students the opportunity to experience first hand responsibilities and demands required to have a career in the large animal science industry.

EC

This is a science equivalency course. Successful completion will count toward a third or fourth credit of science. See pages 14 for details.

SMALL ANIMAL VET SCIENCE

Course: 792
Credit: .5
Grade: 9, 10, 11, 12
Prerequisite: None
Fee: \$5.00

This is the only class at school with cats and dogs in the classroom! Learn how to keep your pets happy, healthy, and safe with actual classroom animals. You will learn how to perform lifesaving procedures such as CPR and artificial respiration, make diagnoses, and analyze diets and nutrition. You will learn how to bandage an abrasion, stitch a wound, and address any major medical emergency. You will understand what it takes to effectively care for dogs and cats in any situation. This is an ideal class for anyone who loves caring for animals or who wants to pursue a career in a medical field. This class involves opportunities to work with live dogs and cats as well as various other species.

EC

This is a science equivalency course. Successful completion will count toward a third or fourth credit of science. See pages 14 for details.

AGRICULTURE EDUCATION

NATURAL RESOURCES

Course: 793.5
Credit: .5
Grade: 10, 11, 12
Prerequisite: None
Fee: \$5.00

Interested in Wisconsin's natural resources? This course will revolve around the wise use of Wisconsin's natural resources. Learn about conservation practices involved with habitats, ecology, and resource management including hunting, fishing and trapping. Topics may include invasive species, pollution, climate change, renewable energy, soils, water quality, and wilderness survival! Students will have the opportunity to participate in a handful of field trips to learn about careers in natural resources.

Students enrolled in this LHS course have the opportunity to register with Mid-State Technical College to receive Dual Credit. See pages 12-13 for details.



INTRO TO FISH, FORESTRY, & WILDLIFE RESOURCES

Course: 784.5
Credit: 1.0
Grade: 11, 12
Prerequisite: See description
Fee: \$20.00 (includes safety glasses, gloves, and hearing protection)

Love the outdoors? This course will use the school forests extensively for examining and practicing the principles behind good forest and woodlot management including wildlife and habitat management. Investigate three components of this course including fish, forests, and wildlife. These components will include a taste of the following: forestry management practices, forest products, forestry equipment maintenance, fish and fisheries practices, wildlife management, and careers. Students will be given opportunities to meet guest speakers that are in the workforce of fisheries, forestry, and wildlife. Students must wear appropriate clothing for safety and the weather when out at the school forests.

With the assistance of the instructor, students will arrange for their own transportation to and from the school forest and provide applicable proof of vehicle insurance and driver's license.

Because of the inherent risk and safety concerns of this course and to better ensure the well-being of the participants in this course, any student registering for this course must meet the following course enrollment criteria:

- Student has not been subject to an excessive amount of discipline referrals for the previous school year
- Student has a desire to succeed at developing forestry management basic skills
- Student must be willing to engage in extremely focused activity operating power tools (i.e. chain saw)

After consult and review with the instructor and school administration, it shall be the advisor's prerogative to deny any student admittance to this course if they consider the student to be a detriment to the learning environment of the course and/or endangerment to the health and safety of its participants.

Students enrolled in this LHS course have the opportunity to register with Mid-State Technical College to receive Dual Credit. See pages 12-13 for details.



INTRODUCTION TO HORTICULTURE

Course: 786.5
Credit: 1.0
Grade: 10, 11, 12
Prerequisite: None
Fee: \$10.00

Students in this course spend most of their time in the greenhouse, learning and applying real-world skills needed to grow flowers and vegetables as well as diagnose pathogens, prevent disease, and maximize horticultural performance. Students leave the course able to manage a greenhouse, maximize plant growth, and obtain careers in a horticultural field. Students begin by exploring soil science and plant anatomy, learning how a seed becomes a full grown plant while exploring how to maximize plant performance in a garden. As winter turns to spring, students begin working outside to create gardens, plant seeds, and cultivate the growth of delicious vegetables and colorful flowers. Students will gain useful horticultural skills while learning in-depth lessons about botany and plant physiology. At the end of this course, students gain the ability to grow their own food anytime in a backyard garden. In addition, students will build and maintain a nursery, practice pruning techniques, investigate the basics of hydroponics, and learn landscaping construction skills and techniques.

Students enrolled in this LHS course have the opportunity to register with Mid-State Technical College to receive Dual Credit. See pages 12-13 for details.



ART



Courses Required For Graduation From This Department: None

INVESTIGATING ART

Course: 608
Credit: .5
Grade: 9, 10, 11, 12
Prerequisite: None
Fee: \$5.00

Do you love art, but you are not sure what to take? This course offers introductory experiences to the many art courses offered at LHS. Students will explore ideas in clay, metals, drawing, painting, and stained glass. The elements and principles of design will be used to give students the tools they need to be strong problem solvers. Students are assisted in developing their creativity and technical skills in many areas of visual arts.

Students will be expected to pay additional fees for materials beyond the \$5.00 lab fee.

VIDEO ARTS

Course: 641
Credit: .5
Grade: 9, 10, 11, 12
Prerequisite: None
Fee: None

Do you love to create video projects for social media? Are you interested in becoming a professional videographer? This class will emphasize the use of video to create productions on a personal or professional level. Students will gain knowledge and understanding of Audio/Visual equipment, lighting effects, directing, and script writing skills, organization, self-expression, and creativity. Students will then explore Adobe Premiere Pro in order to compile and edit footage, create special effects, and also work with audio and video effects and transitions that allow students to develop finished, well produced videos. **To be successful in this course, most shooting assignments are required to be completed outside of class time.**

A \$50.00 refundable deposit will be required to check out school equipment if students don't have their own video camera.

COMPUTER GRAPHICS

Course: 643
Credit: .5
Grade: 9, 10, 11, 12
Prerequisite: None
Fee: None

Are you interested in a career in graphic design, marketing, or advertising? The emphasis of this course is on commercial art, design, and problem solving skills. This course explores the preparation and execution of advertising art, artwork for publications and logo design. Students will learn how to develop ideas quickly, efficiently, and with greater creativity. Computer applications in graphic design are explored using Adobe Illustrator, PhotoShop, and InDesign. Previous experience in using this software is NOT required. Students interested in marketing, the printing industry, public relations, journalism, advertising, or free-lance art are encouraged to take this course.

DRAWING I

Course: 611
Credit: .5
Grade: 9, 10, 11, 12
Prerequisite: None
Fee: None

Do you want to grow in your drawing skills and explore different media? This course gives students the opportunity grow their technical skills in drawing. In this introductory class, students will have the opportunity to develop their ability to draw through observation of still-lives, nature, and portraits. Students will receive feedback from each other and the teacher to help them grow in their art skills. Illustration and cartooning techniques (anime/manga) are NOT covered in this course. Various art mediums such as graphite and charcoal will be explored through technical practice and assignments. This course is designed to help students build an art portfolio highlighting their realistic drawing skills.

Students must earn a C or better to move to Level II.

DRAWING II, III, IV

Course: 612, 613, 614
Credit: .5
Grade: 10, 11, 12
Prerequisite: Grade of C or better in previous course
Fee: None

The advanced courses are for any student who wants to develop their skills and knowledge in the visual arts. Emphasis is on individual involvement through ideas, self expression, creativity, and design for concentrated work in drawing and printmaking. Students will also learn the basic principles of design. Each student will be expected to participate in a student art show at the end of the year. This course is a combination of required and independent study assignments. Color pencil techniques are covered in Drawing II.

ART

PAINTING I

Course: 616
Credit: .5
Grade: 9, 10, 11, 12
Prerequisite: None
Fee: \$8.00

Are you interested in painting on canvas and becoming a better artist? This course gives you the opportunity to explore painting. In the introductory course, students will have the opportunity to develop his/her ability to draw from the real world, and learn the basic elements of design. Techniques will be offered in acrylics and watercolor. Students will study color theory, composition, and color mixing. Blending and brush techniques will also be covered in the course.
Students must earn a C or better to move to Level II.

PAINTING II, III, & IV

Course: 617, 618, 619
Credit: .5
Grade: 10, 11, 12
Prerequisite: Grade of C or better in previous course
Fee: \$10.00

The advanced courses are for students who want to develop their skills and knowledge in the visual arts. Emphasis is on individual involvement through ideas, self expression, creativity, and design for concentrated work in painting and canvas building. Students will learn how to use oils in the course and also learn the basic principles of design. Each student will be expected to participate in a student art show at the end of the year.

FIBERS I

Course: 636
Credit: .5
Grade: 9, 10, 11, 12
Prerequisite: Classes are sequential
Fee: \$10.00

Are you thinking about going into fashion design, education, or a personal business? Explore fibers processes related to fabric dyeing including tie dye, batik, and silk painting. In addition, you will learn surface design techniques such as printmaking, stenciling, and mixed media. The class is based on the elements and principles of design with an emphasis on color theory and composition. You will also develop problem solving and creative thinking skills.

Students will be expected to pay additional fees for materials beyond the \$10.00 lab fee.

Students must earn a C or better to move to Level II.

FIBERS II

Course: 637
Credit: .5
Grade: 10, 11, 12
Prerequisite: Grade of C or better in previous course
Fee: \$10.00

Students will expand their knowledge of fibers techniques. They will learn to create 3D fabric constructions, weavings, bead mosaics, and other mixed media techniques. The class is based on the elements and principles of design with an emphasis on color theory and composition. Students will also develop problem solving and creative thinking skills.

Students will be expected to pay additional fees for materials beyond the \$10.00 lab fee.

FIBERS III & IV

Course: 638, 639
Credit: .5
Grade: 10, 11, 12
Prerequisite: Grade of C or better in previous course
Fee: \$10.00

Fibers III and IV are based on the creative use of fibers. Emphasis is on individual problem solving through ideas, self-expression, creativity, and design for concentrated work in fibers. Projects may include a combination of fiber with other media such as clay, metal or wood. Students will work in a manner that shows their unique point of view and creative self-expression. Each student will be expected to exhibit a piece in the student art show at the end of the year.

Students will be expected to pay additional fees for materials beyond the \$10.00 lab fee.

ART

CLAY AND SCULPTURE I

Course: 621
Credit: .5
Grade: 9, 10, 11, 12
Prerequisite: None
Fee: None

Ceramics covers a variety of hand building methods and wheel throwing. Clay and Sculpture explores processes and techniques used in sculpture and ceramic design. Sculpture materials may include wood, plaster, paper, metal, or fibers. The elements and principles of design will be covered throughout these courses.

Students must earn a C or better to move to Level II.

CLAY AND SCULPTURE II, III, & IV

Course: 622, 623, 624
Credit: .5
Grade: 10, 11, 12
Prerequisite: Grade of C or better in previous course
Fee: None

These three courses are based on the creative use of sculpture and ceramic techniques. Emphasis is on individual problem solving through ideas, self-expression, creativity, and design. Projects may include a combination of media such as clay, metal, fibers, glass, or wood. Students will work in a manner that shows their unique point of view.

JEWELRY, FABRICATION, CASTING AND GLASS WORKS I

Course: 601
Credit: .5
Grade: 9, 10, 11, 12
Prerequisite: None
Fee: \$10.00

This course explores the process and techniques in jewelry and glass design. Glass techniques may include stained glass, mosaic, and fused glass pieces. Jewelry design includes lost wax casting, sheet metal shaping, soldering, and finishing. The class is based on the elements and principles of design with an emphasis on shape and form. Students will also develop problem solving and creative thinking skills.

Students will be expected to pay additional fees for materials beyond the \$10.00 lab fee.

Students must earn a C or better to move to Level II.

JEWELRY FABRICATION, CASTING AND GLASS WORKS II, III, & IV

Course: 602, 603, 604
Credit: .5
Grade: 10, 11, 12
Prerequisite: Grade of C or better in previous course
Fee: \$10.00

These three courses are based on the creative use of jewelry and glass techniques. Emphasis is on individual problem solving through ideas, self-expression, creativity, and design. Projects may include a combination of media such as clay, metal, fibers, glass, stone, or wood. Students will work in a manner that shows their individual artist style.

Students will be expected to pay additional fees for materials beyond the \$10.00 lab fee.

DIGITAL ART

Course: 628
Credit: .5
Grade: 9, 10, 11, 12
Prerequisite: None
Fee: \$3.00

This course concentrates on the creation of digital drawings, animations, paintings, and designs. Students will explore the use of the Adobe programs Photoshop and Illustrator to create digital art. Students will learn about composition and color theory, along with how to create with a drawing pen and tablet. Experience using the programs is not required. Student interested in drawing, painting, and digital art are great candidates for this class.

ART

PHOTOGRAPHY I

Course: 631
Credit: .5
Grade: 9, 10, 11, 12
Prerequisite: None
Fee: \$5.00

Photography is a popular form of art. This course will concentrate on how to use a digital camera and its functions. Students will learn how to use the Adobe programs Photoshop and Lightroom to edit images. The course is a mix of straight photography and digital experimenting with images. **To be successful in this course, most shooting assignments are required to be completed outside of class time.**
It is highly suggested that students have their own SD card.

Classroom Digital cameras are available for a 3 day check out with a \$50 refundable deposit.

Students must earn a C or better to move to Level II.

PHOTOGRAPHY II & III

Course: 632, 633
Credit: .5
Grade: 10, 11, 12
Prerequisite: Grade of C or better in Photography I
Fee: \$10.00

This course is a continuation in the study of straight photography techniques using film and digital cameras. Students will also explore a unit in traditional film and darkroom photography. The course will cover various creative alternative processes. Famous photographers will also be examined during the term. Students may use their own digital camera for this course. **To be successful in this course, most shooting assignments are required to be completed outside of class time.**

Film cost \$6.00 for additional rolls purchased.

Classroom Digital and film cameras are available for a 3 day check out with a \$50 refundable deposit.

PHOTOGRAPHY IV

Course: 634
Credit: .5
Grade: 10, 11, 12
Prerequisite: Grade of C or better in Photography I, II and III
Fee: \$5.00

Students who have taken all three levels of photography may take this independent study course. Students will be given time to create their own portfolio of work with emphasis on a theme. It is recommended that student have their own camera for this course, be it digital or 35mm. Film students will be required to purchase their own paper and flash drive. **To be successful in this course, most shooting assignments are required to be completed outside of class time.**

Classroom Digital cameras or film cameras are available for a 3 day check out with a \$50 refundable deposit.

AP ART HISTORY

Course: 625, 225
Credit: 1.0
Grade: 11,12
Prerequisite: None
Fee: None

AP Art History is an introductory college course in art history which includes the study of architecture, sculpture, painting, and other art forms within societal influences in history and culture. Students will critically analyze art and history starting with ancient civilizations through the 21st century modern works. No prior exposure to art history is required, however, students who have interest in humanities, such as history, literature and art, are encouraged to enroll. **This course is team taught by a social studies teacher and an art teacher.**

Students will receive a .5 social studies credit and a .5 art elective credit for this course.

Students choosing to take the AP exam will be charged approximately \$95.00. The cost of the AP exam is determined by the College Board.

Students passing the AP Exam may be able to use the credits towards their humanities requirement in college.



ART

Art

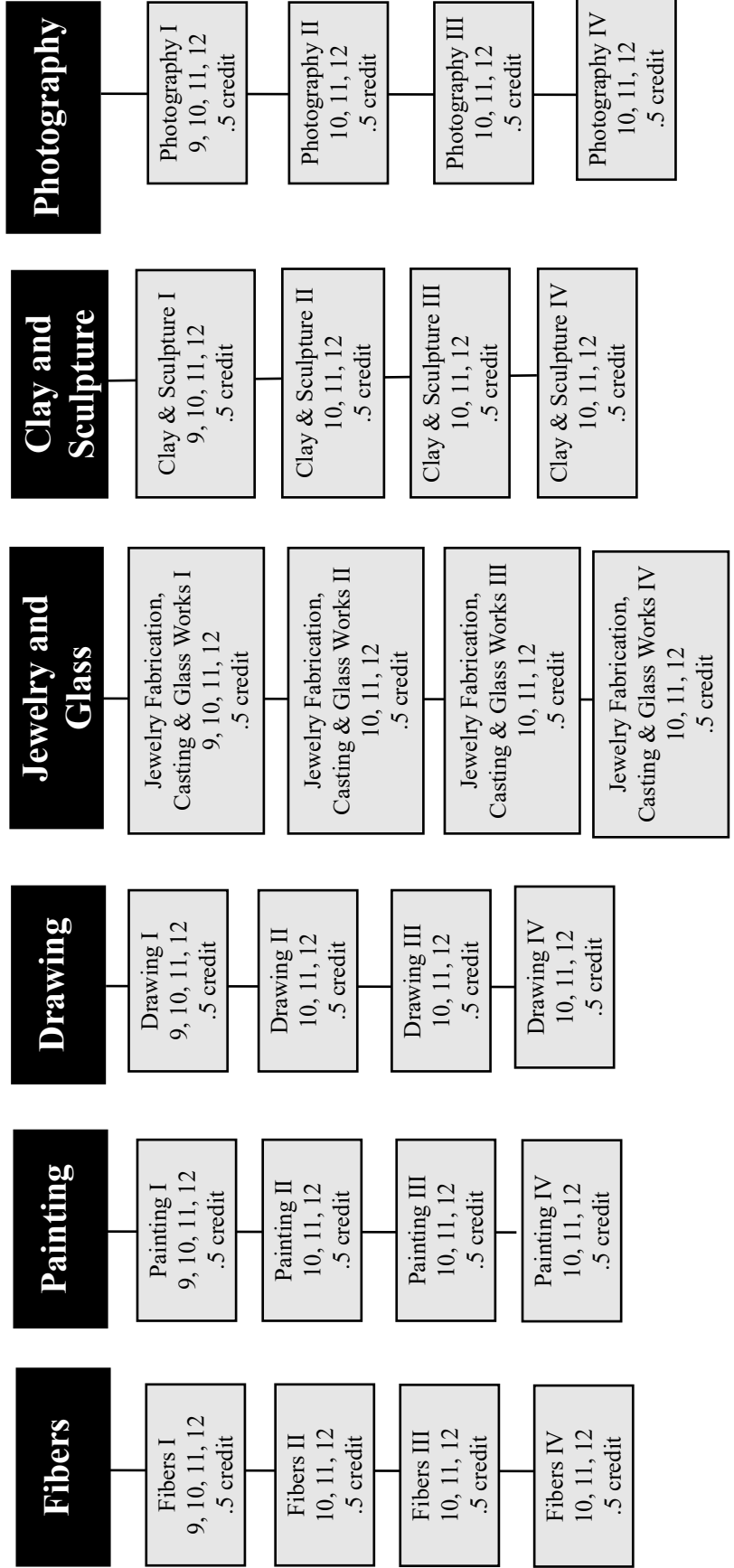
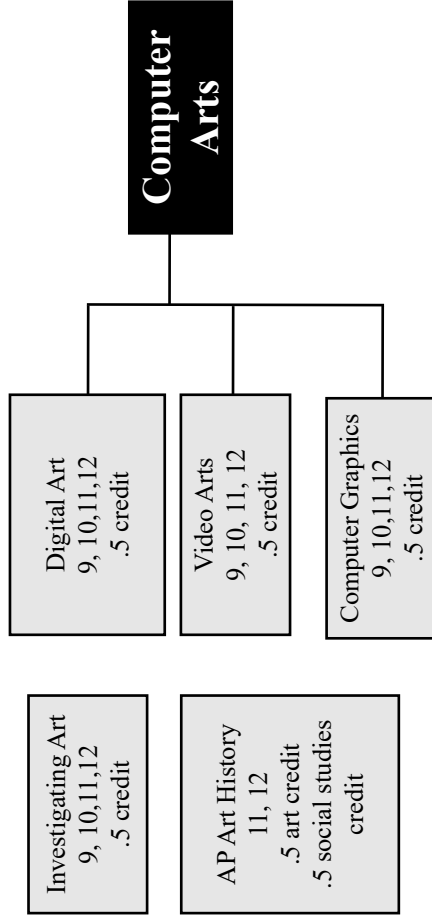

BUSINESS EDUCATION, COMPUTER SCIENCE AND MARKETING EDUCATION



Courses Required For Graduation From This Department: 0.5 Credit
IT Fundamentals I

BUSINESS EDUCATION

PERSONAL FINANCE

Course: 506
Credit: .5
Grade: 11,12
Prerequisite: None
Fee: None

You will be plunged into a world of financial options from the first day you walk out of school. Along with this comes making many crucial decisions that can, and will, affect your entire life. This course covers many important topics to help you make wise financial decisions. Topics covered will be: money management strategies, consumer protection strategies, banking, the importance of good credit, fundamentals of investing (stocks, bonds, mutual funds), income tax return preparation, housing, risk management (insurance), and retirement planning.

This course satisfies the Financial Literacy graduation requirement.

PERSONAL FINANCE (BLENDED INSTRUCTIONAL DELIVERY)

Course: 506.1
Credit: .5
Grade: 11,12
Prerequisite: Student must have PRIDE status
Fee: None

You will be plunged into a world of financial options from the first day you walk out of school. Along with this comes making many crucial decisions that can, and will, affect your entire life. This course covers many important topics to help you make wise financial decisions. Topics covered will be: money management strategies, consumer protection strategies, banking, the importance of good credit, fundamentals of investing (stocks, bonds, mutual funds), income tax return preparation, housing, risk management (insurance), and retirement planning.

Students enrolled in this course will be taught using a blended curriculum of online and classroom experiences. The first week of the course will be taught in the classroom. After students are familiarized with the course and the expectations, the class will move to an online format with students meeting a minimum of once a week in the classroom.

This course satisfies the Financial Literacy graduation requirement.

ACCOUNTING I

Course: 500
Credit: .5
Grade: 10, 11, 12
Prerequisite: None
Fee: None

There is a whole world of opportunities waiting for you in accounting. You could work for an accounting firm, a corporation, a small business, the government, or a non-profit organization. Accounting is an excellent foundation for starting your own business. It is recommended that you take accounting if you plan to go to college or technical college for any business or marketing degree. Many other majors also require accounting.

You will learn the accounting cycle for a small service business and basic accounting practices for keeping financial records of a business. The workbook is now online; therefore, computers are used throughout the course.

ACCOUNTING II

Course: 503.5
Credit: 1.0
Grade: 11,12
Prerequisite: Accounting I
Fee: None

Anyone planning to major in business or marketing should take Accounting II. Many high school students declare business as their major or program beyond high school. This course covers the basics of business transactions: how to complete the entire accounting cycle for small, single-owner service and merchandising businesses, detailed accounting for inventories, cash, receivables, and fixed assets.

Students enrolled in this LHS course have the opportunity to register with Mid-State Technical College to receive Dual Credit. See pages 12-13 for details.

BUSINESS EDUCATION, COMPUTER SCIENCE AND MARKETING EDUCATION

BUSINESS COMMUNICATIONS

Course: 510
Credit: .5
Grade: 12
Prerequisite: None
Fee: None

Business Communications is a one term course offered to seniors that will benefit those going to the technical college, university, and/or those entering the work-force. The primary goals of the course are to explore applied communication and to show the relevance of reading, writing, speaking, presenting, and listening in workplace situations. Projects, cooperative learning, and various forms of technology will be utilized throughout the class to cover units such as Understanding the Communication Process, Communication for Employment, Communication in the Workplace, Digital Communication, Proposals and Reports, Oral Presentation Skills, and Technical Writing.

EC

This is an English equivalency course. Successful completion will count toward .5 credit of English. See pages 14 for details.



Students enrolled in this LHS course have the opportunity to register with Mid-State Technical College to receive Dual Credit. See pages 12-13 for details.

COMPUTER APPLICATION COURSES

DIGITAL CREATIONS IN DESKTOP PUBLISHING

Course: 562
Credit: .5
Grade: 9, 10, 11, 12
Prerequisite: None
Fee: None

This one term course will allow students to develop skills in creating professional digital and print media. Students will learn techniques of effective design to create a variety of print ready publications and digital media for the web which will enhance communication in the business environment. Digital tools and the latest production software, Microsoft Publisher and the Adobe CC suite, will be incorporated in this project-based course.

IT FUNDAMENTALS I

Course: 561
Credit: .5
Grade: 9, 10, 11, 12
Prerequisite: None
Fee: None

This one term course is a general survey of computers and computing. It is designed to give students a hands-on overview about the main computer concepts expected in today's world: current software applications (Microsoft Office), hardware components, programming, and graphics. In addition, students will study the social and ethical impact associated with computer use, as well as computer history and Internet safety.

IT FUNDAMENTALS II- INTEGRATED MICROSOFT OFFICE

Course: 573.5
Credit: .5
Grade: 10, 11, 12
Prerequisite: IT Fundamentals I
Fee: None

This one term course will expand your knowledge of the Microsoft Office Suite and build confidence in dealing with new technology and software. This project-based course will incorporate Microsoft Word, Excel, PowerPoint and Access concepts. Current software in the Windows environment is used to enhance the student's ability to work with digital sound manipulations and video editing. This course provides an opportunity to earn Microsoft Office certifications.

Students enrolled in this LHS course have the opportunity to register with Mid-State Technical College to receive Dual Credit. See pages 12-13 for details.



INTRODUCTION TO WEBSITE DESIGN

Course: 563
Credit: .5
Grade: 10, 11, 12
Prerequisite: IT Fundamentals I
Fee: None

The demand for instant information has generated a variety of occupations related to the design, development, and maintenance of Internet content. Introduction to Web Site Design is a one term course that will allow students to explore the creation and design of web sites for computers and mobile devices. Students will design a variety of websites with animations, graphics, and mobile apps in their projects using modern design techniques.

COMPUTER PROGRAMMING COURSES

PROGRAMMING I

Course: 564
Credit: .5
Grade: 10, 11, 12
Prerequisite: IT Fundamentals I
Fee: None

This one term course provides an introduction to computer programming. Students will be introduced to basic programming structures and current programming practices in Scratch, a simple, interactive programming language and then transition into Java. Students will design and create projects in both languages. This is an excellent introductory programming course and is a prerequisite for all other programming courses.

PROGRAMMING II

Course: 568
Credit: .5
Grade: 10, 11, 12
Prerequisite: Programming I
Fee: None

This one term course will build on programming structures and practices introduced in Programming I. The course will be taught in Java, the current language of choice in the educational and professional computing world. Students will further their understanding on topics including: variables, input and output, decision making, loops, arrays, methods, classes and graphics. An introduction to game design and development will also be addressed through project-based assignments.

ADVANCED PROGRAMMING

Course: 569
Credit: .5
Grade: 10, 11, 12
Prerequisite: Programming II
Fee: None

This one term course will review and extend the concepts of Programming II through project-based assignments. Java will be used to further investigate object-oriented programming and class structure. Advanced topics covered include: linked lists, data structures, and searching and sorting algorithms. This course will prepare students for technical colleges, four year universities, or direct employment in the computer industry.

COMPUTER SUPPORT COURSES

A+ COMPUTER MAINTENANCE & REPAIR

Course: 577.5
Credit: 1.0
Grade: 10, 11, 12
Prerequisite: IT Fundamentals I
Fee: None

Having a technical foundation is critical in today's society. A+ is a two term course that will provide a strong technical background within the areas of computer hardware and software. Students will receive instruction and hands-on experience in the areas of: PC hardware, computer safety, peripheral hardware devices, operating systems-Windows, Mac, and Linux, preventive maintenance, and customer service. The course is based on the CompTIA's A+ certification objectives. This course allows students to build and maintain their own computer and culminates with a student built computer network that includes a LAN game.

Students enrolled in this LHS course have the opportunity to register with Mid-State Technical College to receive Dual Credit. See pages 12-13 for details.

STUDENT HELP DESK

Course: 578.5
Credit: .5
Grade: 11, 12
Prerequisite: IT II or A+ Computer Maintenance & Repair or Teacher Consent
Fee: None

Student Help Desk is a one term course that will allow students to repair a variety of technical problems(hardware and software) and earn IT certifications. Students will receive service requests and take the appropriate actions to resolve the issue to simulate technology problems faced in today's business world. In addition, students will also work toward obtaining the PC Pro certification. It is highly recommended students take the A+ Computer Maintenance and Repair course before enrolling in this course. This class may be repeated to obtain other Information Technology certifications(Networking, Ethical Hacking, etc.) with instructor approval.

Students enrolled in this LHS course have the opportunity to register with Mid-State Technical College to receive Dual Credit. See pages 12-13 for details.



BUSINESS EDUCATION, COMPUTER SCIENCE AND MARKETING EDUCATION

MARKETING EDUCATION

INTRODUCTION TO MARKETING & BUSINESS

Course: 550
Credit: .5
Grade: 9, 10, 11,12
Prerequisite: None
Fee: None

Marketing and Business involves the many activities needed to get products from producers to consumers. It is one of the most exciting and vital career areas you could ever explore! This class is a must for all students who plan on succeeding in our very competitive free enterprise system.

Students will explore all of the functions of marketing. Students will also investigate the consumer approach of how marketing affects all consumers. Specifically, students will discuss: the world of marketing, marketing information management, product planning, pricing, distribution, financing, personal selling, and promotion. In order to gain real world experience in the marketing and business fields, students will participate in various scenarios, simulations, and projects throughout the course.

This course is the foundation course to Sports and Entertainment Marketing and Marketing Principles.

SPORTS, EVENT, & SOCIAL MEDIA MARKETING

Course: 553
Credit: .5
Grade: 11,12
Prerequisite: Intro to Marketing and Business
(Students may take Intro to Marketing and Business concurrently.)
Fee: None

The Marketing and Business field is seeing exponential growth in the Sports and Entertainment Industry. Now a \$600 billion industry, the Sports and Entertainment Industry has become a dominant presence not only in the U.S., but also in the rest of the world. The Sports and Entertainment Industry encompasses everything from movies, music, television, and computer games to social media, merchandising, theater, tourism, theme parks, and professional and recreational sports.

Students will learn the fundamental principles and concepts identified with the Sports and Entertainment Marketing Industry through real life scenarios and simulations. Students in this course will have the option of developing their own professional sports franchise or planning a concert tour for a major entertainment act. Within this project, students will develop logos, plan stadium or stage layouts, design and determine ticket prices, develop merchandise, and promote their team or concert. Students will be required to plan, implement, and evaluate school and community needs related to Sports and Event Marketing through the completion of cause marketing projects such as Sportainment Night and the Dodgeball Classic. Students will utilize social media to promote this event and analyze the effectiveness of their content and its impact on the event.



Students enrolled in this LHS course have the opportunity to register with Mid-State Technical College to receive Dual Credit. See pages 12-13 for details.

STARTING A SMALL BUSINESS

Course: 526.5
Credit: .5
Grade: 10, 11,12
Prerequisite: None
Fee: None

An entrepreneur is a person who attempts to earn a profit by taking the risk of operating a business enterprise. Do you want to be your own boss? If you answered yes, then this class is a must and will help you understand what it is like to be an entrepreneur in today's global markets. You will learn what is involved in starting a business.

This course is an introduction to what a business is, how it operates, and how it is managed. Students in this course will identify forms of ownership, the processes used in production, marketing, finance, personnel, management, and conducting business internationally. Specifically, students will be creating their own small businesses through the completion of a business plan.



Students enrolled in this LHS course have the opportunity to register with Mid-State Technical College to receive Dual Credit. See pages 12-13 for details.

DIGITAL MEDIA & LIVE BROADCAST

Course: 558
Credit: .5
Grade: 10*, 11, 12
Prerequisite: None
Fee: None

In the Digital Media & Live Broadcast class, students will be introduced to the world of video board productions, where they will use state-of-the-art technology and software to create event content. Moreover, students will learn how to produce and run quality live broadcasts using a live streaming platform. The skills learned translate directly into real-world industry applications. Students in this class will be responsible for producing video board digital content as well as participating in the set-up and production of live streamed events. Students will also be expected to participate in a minimum of three events outside of class during the term as part of their grade. The course enrollment will be capped at 15 students.

*Note: Freshmen students wishing to take this elective as a sophomore will need instructor approval prior to enrollment.

BUSINESS EDUCATION, COMPUTER SCIENCE AND MARKETING EDUCATION

MARKETING PRINCIPLES

Course: 554.5
Credit: 1.0
Grade: 12
Prerequisite: C average in any business or marketing class
Fee: None



Marketing Principles is an advanced level marketing course utilizing Mid-State Technical College (MSTC) curriculum, textbook, and on-line resources. Whether you are majoring in a business field or non-business field, there are several reasons to study marketing. Marketing plays an important role in society. It is vital to business success, offers outstanding career opportunities, and affects your life everyday as a consumer.

A variety of interactive and hands-on activities and methods will be used to help students analyze the major components of the marketing process and how they relate to real world examples. Topics to be covered include marketing planning and segmentation, buying behavior, bringing new products to market, developing distribution channels, exploring various advertising and promotional methods, and making effective product mix decisions. Students will also be responsible for operating the school store.

Introduction to Business and Marketing is highly recommended and can be taken concurrently. Students enrolled in this LHS course have the opportunity to register with Mid-State Technical College to receive Dual Credit. See pages 12-13 for details.

MARKETING & BUSINESS WORK EXPERIENCE

Course: 557
Credit: .5, 1.0, 1.5
Grade: 12
Prerequisite: C average in any business or marketing class
Fee: None

This program is a paid work experience for seniors striving for careers in Marketing and Business. There are many options for this work experience. Students may be dismissed early for the supervised work experience if their schedule permits. Get a head start and gain valuable occupational/career skills now by enrolling in Marketing & Business Work Experience.

Students must apply for this program through a marketing or business teacher. Selection is based on skills, employability, attitude, personality, attendance, and successful completion of the application process. Please note, students will be required to provide proof of employment two weeks before each term. Should a student register and not have a job, the student may be placed in study hall or required to add a class.

This course can be taken for 1, 2 or 3 terms.

Required course to be taken at the same time with work experience: No. 554.5 Marketing Principles.

Business and Marketing

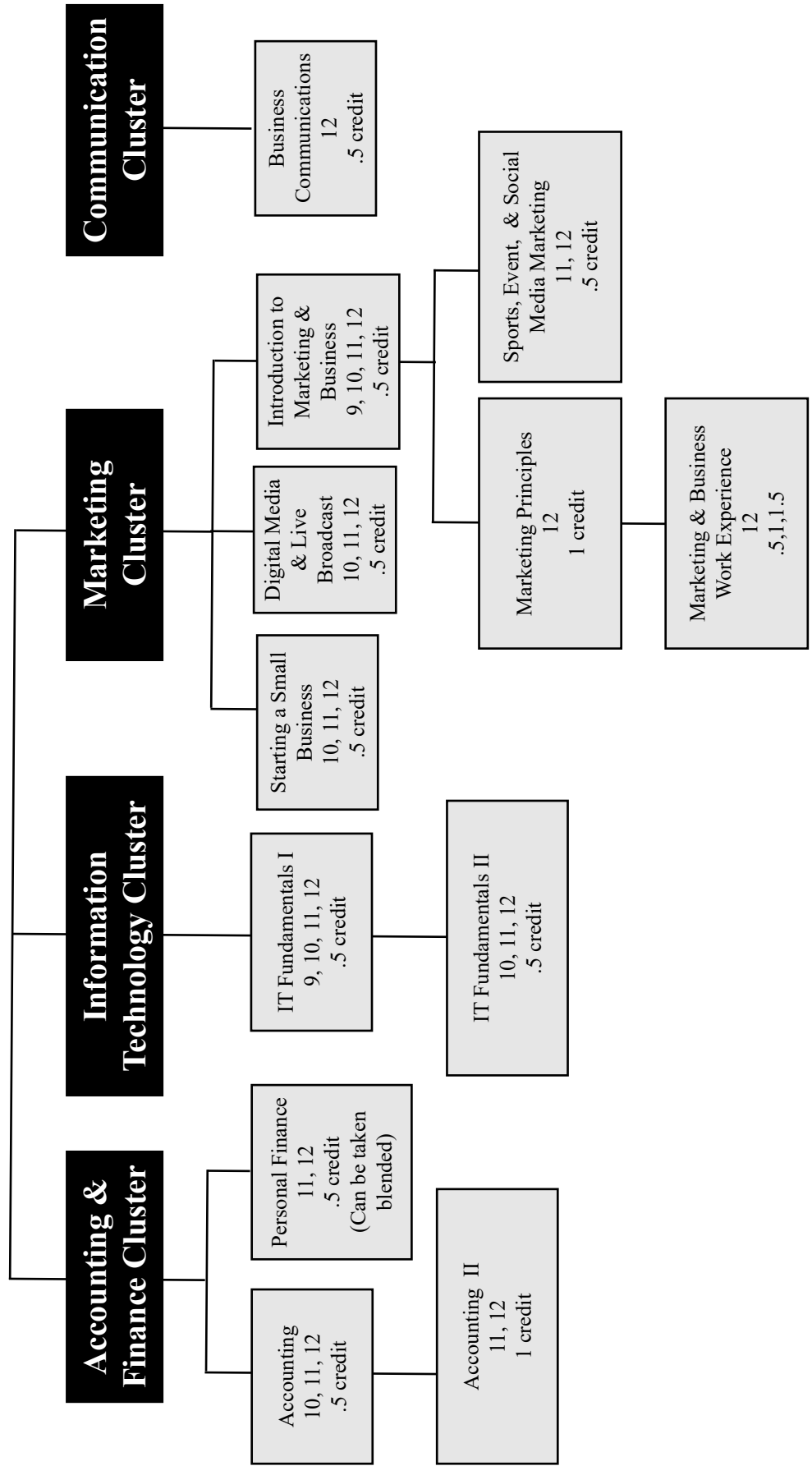

Computer Science

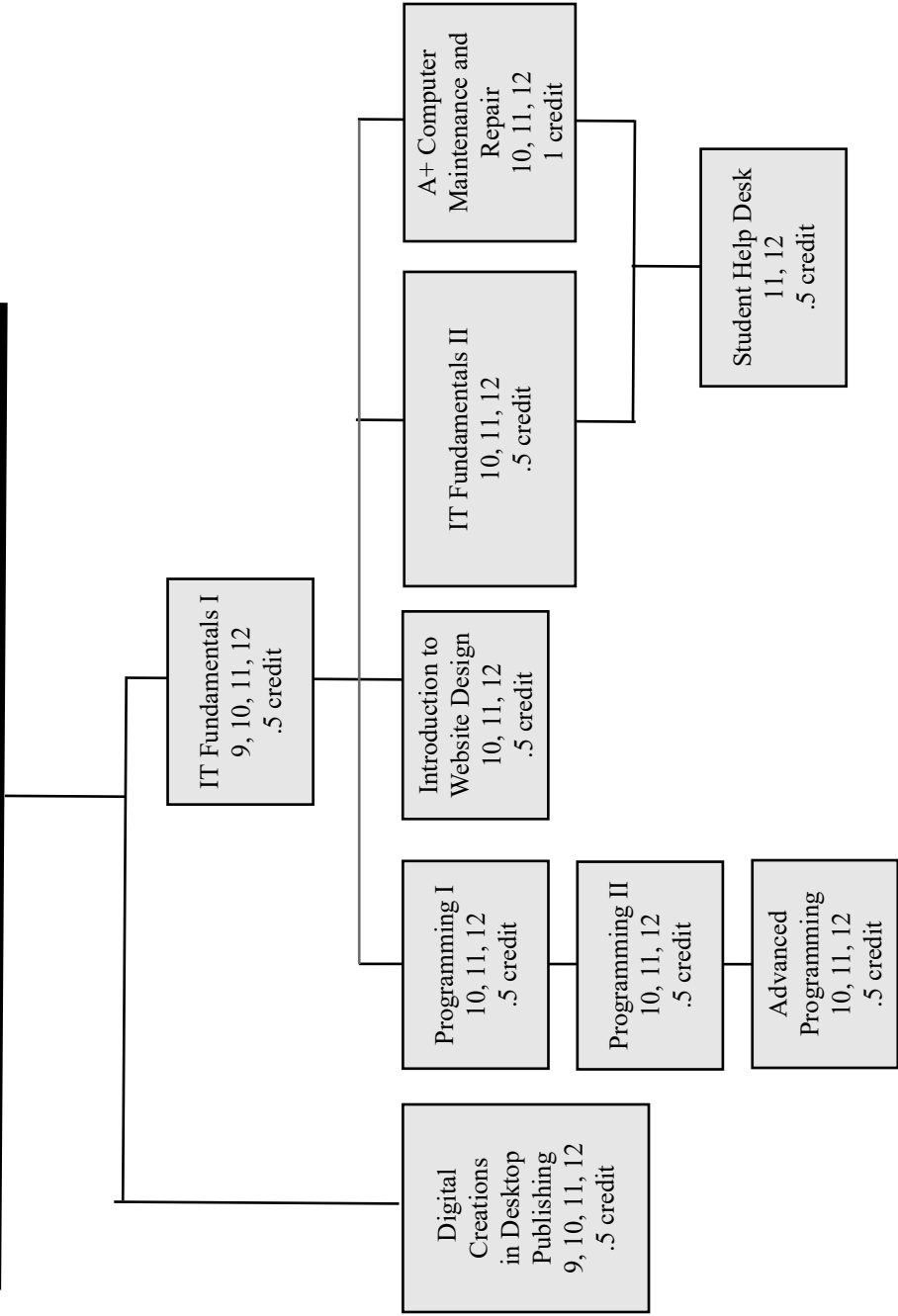

ENGLISH/LANGUAGE ARTS



Courses Required For Graduation From This Department: 4 Credits

1 credit of English I, 1 credit of English II, and 2 additional English credits are required

ACCELERATED ENGLISH I/II This advanced English course condenses the curricula of two year-long language arts courses into one year: English I (ninth grade) and English II (tenth grade). The course provides instruction in the reading, writing, speaking, and language skills students will find necessary for success in high school and beyond. Students will read classic and contemporary works—a blend of literary and informational text from a variety of genres—and will write compositions that are informative/explanatory, persuasive/argument, narrative and poetic in nature. Readings include, but are not limited to, *The Odyssey*, *Lord of the Flies*, *Macbeth*, and various autobiographical novels.

Course: 104
Credit: 1.0
Grade: 9
Prerequisite: See course description
Fee: None



As such, students will experience a faster pace, less review and repetition, and more opportunities to engage themselves with the content in an abstract manner. Because of the accelerated academic pace, students should be prepared for outside-of-classroom work expectations to rise significantly. Students who qualify and successfully complete the course may then enroll in more rigorous, junior-level, classes as sophomores, working to complete their remaining three credit requirements of English for graduation.

To better ensure student success in this accelerated learning environment, current eighth grade students are required to meet these two mandatory criteria: 1. Have a Scholastic Reading Inventory (SRI) Lexile of at least 1265, 2. Have a grade of an A or a B in 8th grade English. In addition, students must meet one other criteria: either a qualifying test score (80%) on an English/Mechanics test or score at or above the 85 percentile on the Forward Exam (or its equivalent), or a district writing sample with an advanced score.

Students may be moved to English I A if they are not successful in the first part of Accelerated English. Students must earn a grade of B or better term A to continue in this course. Students who do not earn a grade of B or better will need to take English II in tenth grade.

ENGLISH I This required, two-trimester, introductory English course provides instruction and practice in the reading, writing, speaking and language skills students will find necessary for success in high school and beyond. Students will study literary works including drama, mythology, and classical literature. Students will combine literature with their writing practice in a variety of genres including informative/explanatory, and persuasive/argument. Units include, but are not limited to: fictional short stories, *Romeo and Juliet*, *The Odyssey*, a choice novel, and vocabulary.

Course: 103
Credit: 1.0
Grade: 9
Prerequisite: None
Fee: None



ENGLISH II This required sophomore course provides instruction and practice in reading, writing, speaking, and language skills students will find necessary during and beyond high school. Students can expect to study several thematic units that incorporate a blend of literary and information text, as well as a variety of writing (informative/explanatory, persuasive/argument, and narrative) in extended process work and on-the-spot (demand) writing. Students develop their speaking and listening skills through impromptu and sustained discussion activities and presentations. While students learn how to strengthen their ideas and organize, they also deepen their understanding of how sentence fluency, word choice (including vocabulary), voice, and conventions make writing, whether it's their own or another's, more effective.

Course: 106
Credit: 1.0
Grade: 10
Prerequisite: None
Fee: None



ENGLISH III This course is designed to extend and strengthen the basic reading, writing, listening, and speaking skills learned in English II. Various themes may include: war, loneliness, roots, the “American Dream,” and alienation. Themes are explored through the reading of novels, plays, short stories, and poems. There is an emphasis on American literature. Class discussions, research, and individual/group presentations will enhance students’ speaking and listening skills. Frequent compositions are expected of all students.

Course: 115
Credit: 1.0
Grade: 11
Prerequisite: None
Fee: None

This course is not open to students who have taken American Literature and Composition.



ENGLISH/LANGUAGE ARTS

ENGLISH IV: LITERATURE

Course: 116
Credit: .5
Grade: 12
Prerequisite: None
Fee: None

This single-term course is designed to extend the reading, writing, and discussion skills developed in junior-level English courses. This course will focus on literary analysis and students will demonstrate their analysis through writing, discussion, and summative assessments. The literature explored comes from a wide variety of time periods, countries, and perspectives. Further, students can expect to analyze literature in the form of novels, short stories, and plays.



ENGLISH IV: COMPOSITION

Course: 117
Credit: .5
Grade: 12
Prerequisite: None
Fee: None

This single-term course is for seniors who are looking to strengthen reading and writing skills through a focused study of grammar and composition. Students can expect to read and analyze both fiction and non-fiction/informational text related to 21st Century Skills and other course themes. Grammar studies focus on the specific skills that students need most to be college and career ready. Composition work may include informative, argumentative, and/or narrative genre. Class activities and practice will include independent and collaborative work.



AMERICAN LITERATURE AND COMPOSITION

Course: 112
Credit: 1.0
Grade: 11, 12
Prerequisite: Must have received an A or B in English II.
Fee: None

This course offers a study of American writers and their contributions to the development of American literature. Students can expect to read and analyze literary and informational texts. Composition will focus on developing the areas of argument; analysis; and the impact of style, purpose, and structure on the author's overall message. Through sustained discussions and formal presentations, students will develop their speaking and listening skills.

This course is not open to students who have taken English III.



AMERICA'S VOICE-LITERATURE

Course: 114, 214
Credit: .5
Grade: 10
Prerequisite: None
Fee: None

America's Voice is a sophomore level, team-taught, two-trimester class. This course will combine the curriculum ideas from English II A with the curriculum time periods from Contemporary American History A. It meets for one class period for two trimesters with students receiving .5 ELA credit for trimester 1 and .5 Social Studies for trimester 2. The class blends American history with America's literary tradition. Students will study the issues in our past (beginning in 1900 through World War II) and will read literature associated with each period. Much of the learning is discussion-based and emphasis is placed on both analyzing literature (novels, short stories and poetry) and writing essays. The course is team-taught by a social studies teacher and a language arts teacher.



APOCALYPTIC LITERATURE

Course: 141
Credit: .5
Grade: 12
Prerequisite: None
Fee: None

This course is a senior-only survey of various works of the apocalyptic fiction genre. The texts explored include several short stories and novels, including a graphic novel. Students will demonstrate their understanding of the themes of the genre through written analysis, group discussions, collaborative projects, and classroom presentations. This course will continue to build on the skills students have acquired in previous English courses, including reading, writing, speaking, and listening skills.



ENGLISH/LANGUAGE ARTS

PUBLICATIONS: YEARBOOK

Course: 170
Credit: 1.0
Grade: 9, 10, 11, 12
Prerequisite: None
Fee: None

NOTE: This class is NOT available for English credit.

Publications is an elective that publishes The Ahdawagam, LHS' yearbook. Production is entirely digital, with web-based page design, and all-digital photography. Students learn journalistic and visual arts skills, including interviewing sources, journalistic writing, word processing, copy editing, layout, design, photography, and photo editing. Out of class work is expected, with students held accountable for meeting submission deadlines.

INTRODUCTION TO THEATRE

Course: 132
Credit: .5
Grade: 9, 10, 11, 12
Prerequisite: None
Fee: None

This beginning survey course of the Theatre Arts focuses on storytelling through writing, verbal and nonverbal communication, character development, and directing from a script. Imagination and creativity are strengthened and developed through social emotional learning skills such as building relationships in social situations, self awareness activities, and self motivation exercises. Students are expected to read, write, perform, collaborate, and respond throughout this course.

ACTING AND PRODUCTION

Course: 135
Credit: .5
Grade: 10, 11, 12
Prerequisite: Theatre experience through class or productions
Fee: None

Note: This class is NOT available for English credit.

Want to be in a play but can't after school? Students interested in acting and/or theatre technology will act, direct, build props and sets, design lighting and sound, develop characters, rehearse, gather costumes, learn makeup and publicity, and perform various scenes in duos and small groups. This intermediate course is designed for acting/producing a final play at the end of the term in a collaborative effort.

ADVANCED DRAMA

Course: 134
Credit: .5
Grade: 11, 12
Prerequisite: Theatre experience through class or productions
Fee: None

Advanced Drama is for the serious theatre student. This course requires more skills and abilities than other theatre courses. In addition to gaining empathy and using responsible decision making, students will compare and contrast ancient Greek plays to modern plays, differentiate comedy and tragedy, and respond to modern theatrical ideas. A major course project is assigned and developed throughout the entirety of the course.

THEATRE TECHNOLOGY

Course: 136
Credit: .5
Grade: 9, 10, 11, 12
Prerequisite: None
Fee: None

Note: This class is NOT available for English Credit.

Hands-on instruction is the base of this course. In addition to learning how to run the PAC, students will learn theatre safety, fly rail system, texture painting, and technical design in set, lighting, and sound. Performance projects and tests to show knowledge are throughout the course. A major collaborative musical design project implementing all these skilled areas will be the main assessment at the end of the course.

You may become a PAC technician by completing this class.

THEATRE CAPSTONE

Course: 142
Credit: .5
Grade: 11, 12
Prerequisite: Completion of Theatre Tech. and/or Acting & Production, or consent of instructor
Fee: None

Note: This class is NOT available for English Credit.

This class is for serious theatre technical students. The Technical Theatre field encompasses lighting, sound, scenic, props, management, costumes, makeup and more. Working at their own pace on a culminating project of their chosen Technical Theatre field, students learn how to execute the planned professional events in the PAC and/or design for an LHS production. This course is career oriented and networks students into a career path in Technical Theatre.

ENGLISH/LANGUAGE ARTS

CREATIVE WRITING

Course: 140
Credit: .5
Grade: 10, 11, 12
Prerequisite: None
Fee: None

This course is designed for anyone who loves to write or is curious about the creative writing process and craft. In this class students will: be introduced to narrative prose, participate in many creative writing exercises, write short personal memoirs, learn all the components that make up a complete story, and write their own original vignettes and a short story in any genre of their choosing. Original works may be submitted to *Bloodstone*, LHS's literary journal.



POETRY

Course: 151
Credit: .5
Grade: 10, 11, 12
Prerequisite: None
Fee: None

This course is a study of the art of writing poetry based on the criteria set forth in the text and models from works chosen by the students and teacher. Assignments include writing and rewriting poetry; analyzing and evaluating classmates' poems and published works; and doing writing, speaking, and research exercises to familiarize the student with figurative language, observation of detail, and poetic structure. Poetry devices are emphasized in this course. Students are expected to keep a file of their work and do an analysis of the work of a contemporary poet. Individual help is given to each student. Original poetry will be submitted to the LHS literary journal, *Bloodstone*.

Students must have a willingness to write poetry on a variety of topics and in a variety of forms.



ENVIRONMENTAL LITERATURE IN THE OUTDOORS

Course: 120, 891
Credit: 1.0 (.5 ELA, .5 P.E.)
Grade: 11, 12
Prerequisite: None
Fee: None

This is a junior-senior level, team-taught, two-trimester class. This course combines the curriculum ideas from the English class Environmental Literature with the curriculum of the Physical Education class Outdoor Education. It meets for one class period for two trimesters with students receiving .5 ELA credit for one trimester and .5 Physical Education for one trimester. The class blends the themes of survival and current environmental topics studies in fiction and non-fiction with the physical activities associated with them (including but not limited to rock climbing, high ropes course, fishing, survival shelters, cross-country skiing, foraging, etc.) as well as evaluating factors that impact safety and promoting positive decision making. The composition component of the course will help students make connections between the literature while explaining the technical skills associated with adventure and outdoor pursuits.

All students interested in this course will need to have an informed consent form on file with the physical education teacher prior to registration.

Students will receive a .5 English credit and a .5 Physical Education credit for this course.



SPEECH COMMUNICATIONS I

Course: 152
Credit: .5
Grade: 10, 11, 12
Prerequisite: None
Fee: None

This course offers students the opportunity to initiate and participate effectively in a range of collaborative discussions in a variety of groups, one-on-one, small groups, and/or teacher-led activities. Students will learn the Monroe Sequence of speech writing by integrating multiple sources of information presented in diverse formats and media in order to make decisions and solve problems of their writing and speaking styles. Students will write and orally present a variety of the following speech formats: dyad, informative, persuasive, impromptu, and a song-lyric speech. Special focus is given to development of poise, confidence, critical listening skills, an evaluation of a speaker's point of view, reasoning, and use of evidence and rhetoric. Speech Communication is required in most colleges, universities, and technical schools, so this course is especially helpful to those students seeking further education beyond high school.

Students will fail this course if they choose not to orally present to the class.



SPEECH COMMUNICATIONS II

Course: 154
Credit: .5
Grade: 10, 11, 12
Prerequisite: Speech Communications I or consent of instructor
Fee: None

This course offers students the opportunity to make strategic use of digital media (e.g., textual, graphical, audio, visual, and interactive elements) in presentation to enhance understanding of findings, and evidence to add interest in the preparation of radio broadcasts, commercials, and demonstration speaking. In addition, a formal debate speaking style will allow students to write arguments to support claims in an analysis of topics or texts using valid reasoning and sufficient evidence. There is an emphasis on adapting the speech structure to the audience with the use of voice, audio-visual aids, and alternative patterns of organization of materials. There is an added emphasis on reading historical and contemporary speeches and the evaluation of them.



ENGLISH/LANGUAGE ARTS

BRITISH LITERATURE AND COMPOSITION

Course: 118
Credit: 1.0
Grade: 11, 12
Prerequisite: None
Fee: None

British Literature is a college preparation survey course. The course's content explores various novels, poems, and tales from a chronological perspective through a variety of literary eras in British literature. Students read both fiction and non-fiction, write expository essays, and develop critical thinking and rhetorical speaking skills.



AP ENGLISH LITERATURE AND COMPOSITION

Course: 121
Credit: 1.0
Grade: 11, 12
Prerequisite: None
Fee: None

This course is intended for students interested in earning college credit while still in high school. In May, students take the national College Board AP Exam, and if they pass, earn college credit. The literature component of the class consists of approximately 50% American, 30% British, and 20% European, ranging from classic to contemporary novels, plays, short stories, poetry, and essays. The composition component of the class focuses on informational, argumentative, and persuasive writing, specifically related to literary analysis, organization, research, and grammar.

Students choosing to take the AP exam will be charged approximately \$95.00. The cost of the AP exam is determined by the College Board.



COLLEGE ENGLISH 101

Course: 101
Credit: .5 LHS credit
3.0 UWSP credits
Grade: 11, 12
Prerequisite: None
Fee: See course description

College English 101 is a trimester long introductory writing course that focuses on the basic techniques of composition, on the composing process with attention to drafts and revisions, and on the coherence and organization of essays. By the end of the trimester, students will have gained experience with understanding and recognizing aspects of the rhetorical situation and making appropriate choices for different purposes and audiences; understanding the conventions of standard written English, including introducing and citing sources; improving critical thinking and reading skills; and applying successful strategies to the writing process, from invention to revision.

Students enrolled in this course will be taught using a blended format of online curriculum accompanied by classroom instruction.

This course is a concurrent enrollment course through UW-Stevens Point. Students taking this course may sign up for concurrent enrollment credit. See page 14 for further details.

Please note: If taking for college credit, the cost for the class and ordering of transcripts may be the responsibility of the student/parent.



COLLEGE ENGLISH 202

Course: 102
Credit: .5 LHS credit
3.0 UWSP credits
Grade: 11, 12
Prerequisite: Successful completion of College English 101
Fee: See course description

College English 202: Critical Writing, Reading, and Research is a trimester long course which is the core college writing course where the primary goal is for students to learn advanced critical reading, writing, and research skills. Students will be presented with multiple opportunities to develop advanced critical thinking skills including analysis, synthesis, and argument of scholarly, source-based texts. As such, reading and writing assignments are primarily focused on writing about scholarly, source-based academic texts. By the end of English 202, students will be able to use these independently located scholarly and academic sources in a way that effectively supports a central claim and is appropriate to the writer's audience and purpose.

Students enrolled in this course will be taught using a blended format of online curriculum accompanied by classroom instruction.

This course is a concurrent enrollment course through UW-Stevens Point. Students taking this course may sign up for concurrent enrollment credit. See page 14 for further details.

Please note: If taking for college credit, the cost for the class and ordering of transcripts may be the responsibility of the student/parent.



ENGLISH/LANGUAGE ARTS

English/Language Arts

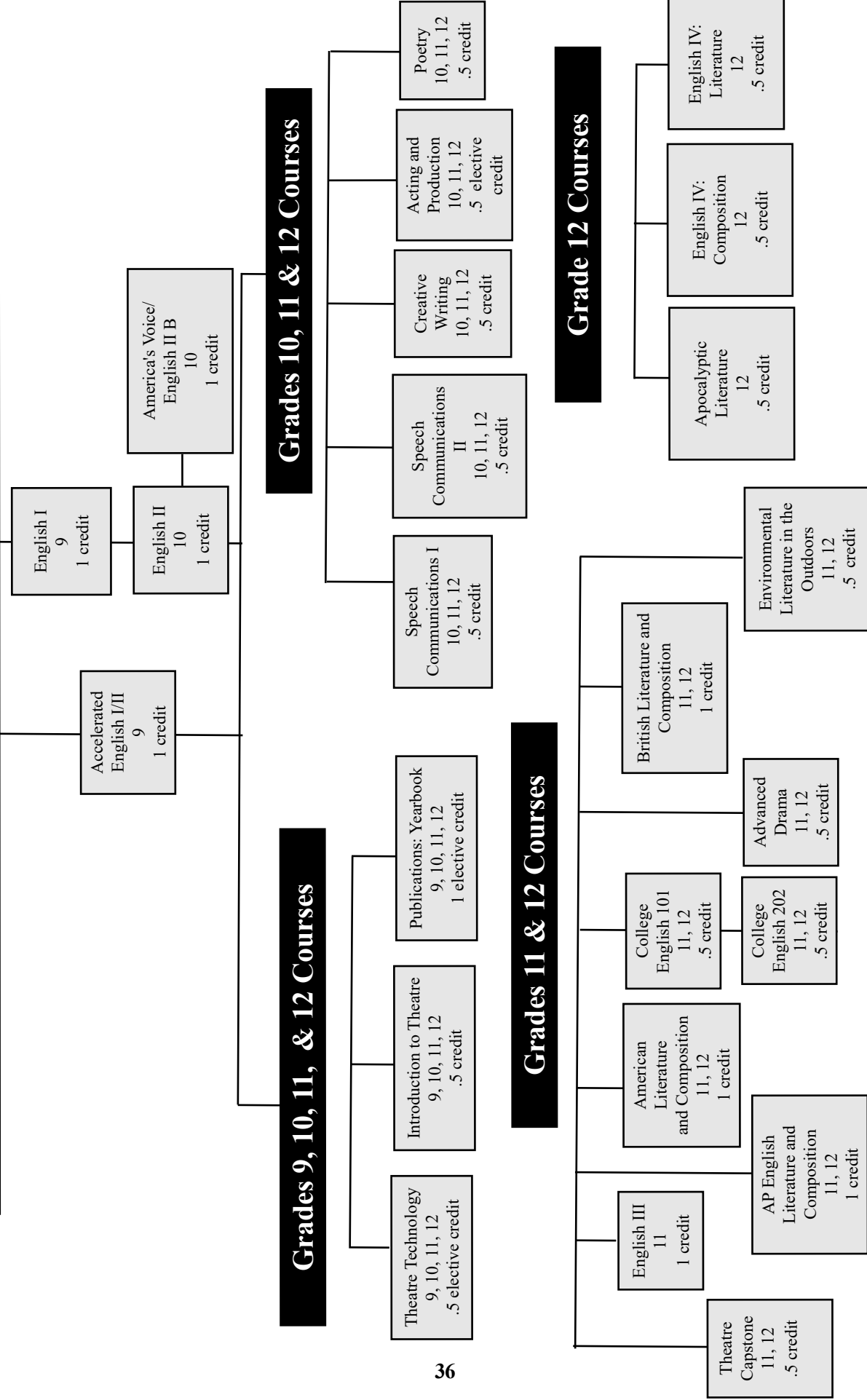

Students who took accelerated English I/II see your counselor for course options.

FAMILY & CONSUMER SCIENCES



Courses Required For Graduation From This Department: None

The use of materials varies from class to class. In all classes, a fee may be charged for supplies and field trips as determined by the class and the instructor. In case of extreme hardship, fees for classes may be waived or reduced.

FAMILY AND HUMAN SERVICES

CHILD DEVELOPMENT

Course: 934.5
Credit: .5
Grade: 10, 11, 12
Prerequisite: None
Fee: \$10.00

Students will examine child development within the context of the early childhood education setting. Students learn to analyze social, cultural, and economic influences on child development; summarize child development theories; analyze development of children ages 3-8; summarize the methods and designs of child development research; analyze the role of heredity and the environment; and examine the role of brain development in early learning. Upon successful completion of course students will earn 3 transcribed credits from Mid-State Technical College.



Students enrolled in this LHS course have the opportunity to register with Mid-State Technical College to receive Dual Credit. See pages 12-13 for details.

HEALTH, SAFETY, AND NUTRITION (BLENDED INSTRUCTIONAL DELIVERY)

Course: 931.5
Credit: .5
Grade: 10, 11, 12
Prerequisite: None
Fee: \$10.00

Are you interested in working with children and want to learn about how to create a safe environment for children? This course will provide you the opportunity to explore the topics of health, safety, and nutrition in an early childhood setting. Course competencies include: integrate strategies that support diversity, cultural responsiveness, and anti-bias perspectives; examine governmental regulations and professional standards as they apply to health, safety, and nutrition; plan a safe early childhood environment; plan a healthy early childhood environment; plan nutritionally sound menus; examine child abuse and neglect issues and mandates; describe Sudden Infant Death Syndrome (SIDS) risk reduction strategies, describe strategies to prevent the occurrence of Abusive Head Trauma (AHT), incorporate health, safety, and nutrition concepts into the children's curriculum. Students will have the opportunity to earn certifications that are necessary in the workplace. This course does NOT meet the health requirement for graduation.



This course may be taken concurrently with Assistant Child Care Teacher/Foundations of Early Childhood Education.

Students enrolled in this LHS course have the opportunity to register with Mid-State Technical College to receive Dual Credit. See pages 12-13 for details.

ASSISTANT CHILD CARE TEACHER/FOUNDATIONS FOR EARLY CHILDHOOD EDUCATION

Course: 937.5
Credit: .5
Grade: 10, 11, 12
Prerequisite: None
Fee: \$10.00

Learn about age appropriate development of young children and how to promote their healthy development through good care and teachable play. Prepare lessons and activities for young children, with the opportunity to facilitate those lessons and activities with children at local early childhood classrooms. Students are required to provide their own transportation when facilitating lessons at early childhood classrooms. Students who are juniors or seniors will have the opportunity to continue working towards their WI Department of Public Instruction Early Childhood Education Certificate as an assistant child care teacher. After completion of their assistant teacher certification, students are eligible to take part in the Early Childhood Youth Apprenticeship program and earn their head teacher certification through the WI DPI.

Additional fees apply for students choosing to get their CPR, AED and First Aid through the American Red Cross. These fees are determined by the Red Cross.



Students enrolled in this LHS course have the opportunity to register with Mid-State Technical College to receive Dual Credit. See pages 12-13 for details.

FAMILY & CONSUMER SCIENCES

INFANT AND TODDLER

Course: 936.5
Credit: .5
Grade: 10, 11, 12
Prerequisite: Assistant Child Care Teacher
Fee: \$10.00



Explore the responsibilities, rewards and challenges required when caring for infants and toddlers. Examine theories related to young children and age appropriate development and learn about early childhood education opportunities and career choices. Class will visit local early childhood education classrooms, observe and interact with young children. Students who are juniors or seniors have the opportunity to work towards a WI Department of Public Instruction Early Childhood Education Certificate as an assistant child care teacher. (Students must also take the Assistant Child Care Teacher course in order to obtain this certification.) Students must complete 20 hours of classroom activities and 10 hours on-the-job experience or observation with children ages birth to three in a child care setting (minimum of 5 hours must involve children ages birth to 1). This is in addition to the ACCT 10 hours of observation in a regulated child care setting.

Additional fees apply for students choosing to get their CPR, AED and First Aid through the American Red Cross. These fees are determined by the Red Cross.

Students enrolled in this LHS course have the opportunity to register with Mid-State Technical College to receive Dual Credit. See pages 12-13 for details.

TEACH AND LEAD

Course: 943
Credit: .5
Grade: 10, 11, 12
Prerequisite: None

Do you have a passion for working with others? Plan on coaching in the future? This is an introductory course to explore the world of teaching. Whether it is at an elementary, junior high, or high school level, you'll learn more about the educational pathway and the skills needed to become a teacher. Gain hands on experience teaching, coaching, or mentoring others. You will observe, explore, participate, and work in the subject area you are passionate about. Learn how to prepare lesson plans, conduct class discussions, give homework assignments, and tests. Students will have the opportunity to job shadow and assist a teacher, teach a mini-lesson within a classroom setting, and among their peers. Transportation to/from volunteer sites is provided by the student, if applicable. See what kind of impact you can make in the lives of students today and get a head start preparing for a rewarding career as a teacher, teaching assistant, or coach.

ON YOUR OWN

Course: 939
Credit: .5
Grade: 11, 12
Prerequisite: None
Fee: \$5.00

Are you looking ahead to the future and thinking about your life beyond high school? Success is the key to independence. Explore your future goals and a plan for getting there. Learn how to land a job and plan for life events. Get educated on banking services, credit cards, loans, basic investment principles, and types of insurance. You'll experience real-life budgeting simulations, explore housing options, determine roommates, and cook a meal on a tight budget. This course will help you handle the transition to independence. If you want to learn strategies and life skills to be a successful young adult, this course is designed for you.

This course satisfies the *Financial Literacy* graduation requirement.

RELATIONSHIPS

Course: 938
Credit: .5
Grade: 9, 10, 11, 12
Prerequisite: None
Fee: None

Strong and healthy relationships are a vital part of life and successful relationships begin with you! This class examines real-world issues and concerns facing teens, young adults, parents, and families. A variety of problem solving activities, discussions, videos, community guest speakers, and creative projects address the skills and characteristics for successful interpersonal relationships. Learn the keys to healthy relationships and effective communication techniques to feel more prepared to make decisions as you face the challenges and stresses of life. This class is also ideal for students seeking a career requiring strong people skills.

FASHION & DESIGN

INTRO TO FASHION DESIGN AND CONSTRUCTION

Course: 912
Credit: .5
Grade: 9, 10, 11, 12
Prerequisite: None
Fee: \$10.00

Open up a whole new world of opportunity by learning about careers in the fashion and textiles industry. Use your creativity to sketch fashion and textile collections. Learn sewing and design technologies and construction methods. Students will create, recycle and redesign clothing, accessories and textile products. Students are expected to pay for fabric and supplies for at least three projects as well as the \$10.00 course fee. A collaborative community project will be completed.

FAMILY & CONSUMER SCIENCES

INTRO TO INTERIOR DESIGN

Course: 930
Credit: .5
Grade: 9, 10, 11, 12
Prerequisite: None
Fee: \$10.00

Be creative while exploring the elements and principles of interior design. Design unique, comfortable, and functional interior spaces. Experiment with a variety of home furnishing resources and design samples, including computer programs to create virtual room designs and floor plans. Examine housing options through the family life cycle. Investigate career opportunities in the housing and interiors industry. Students will conduct research and participate in field trips to area businesses to learn about current trends in home and commercial design, color schemes, and eco-friendly materials. Students will apply knowledge and skills to a final design project.

DESIGN STUDIO

Course: 914
Credit: .5
Grade: 10, 11, 12
Prerequisite: Intro to Interior Design or Intro to Fashion Design
Fee: \$10.00

This course is a continuation of study for students who have successfully completed Intro to interior design or Intro to fashion design and construction. If you want to take your design skills to the next level, this class is for you. Focus on project based, independent learning and develop problem solving and creative thinking skills. Interior design projects will involve room make overs, space planning, and the study of current trends in home materials and design. Fashion projects will include fashion design and construction, upcycling, wardrobe planning, and textile design. Use technology, design tools and materials to develop real-world design solutions. Develop skills needed for the housing, furnishings, and interiors industry and/or the fashion, apparel, and textiles industries. Students are expected to pay additional supplies needed for fashion or interiors projects.

FOODS & NUTRITION

TEEN CUISINE

Course: 921
Credit: .5
Grade: 9, 10
Prerequisite: None
Fee: \$15.00

Focus on the world of food by learning to create appealing and nutritious meals. Food labs will be used to enrich and practice classroom skills. A final project will have students engaged in an entrepreneurship project. Classroom experiences will include reflecting on why people eat the foods they eat, the preparation of foods, safe food handling techniques, consumer issues in food choices, and creativity in recipes.

NUTRITION FOR HEALTHY LIVING

Course: 922.5
Credit: .5
Grade: 10, 11, 12
Prerequisite: None
Fee: \$15.00

Students learn concepts of healthy eating to facilitate the journey of good health across the lifespan. Healthy eating concepts focus on individual decision making and behavior change with sustainable interventions rooted in evidenced-based practice. Students investigate nutrition myth versus fact and explore how policy and environment impact nutritional choice. This course leads students on career track in Health and Wellness promotion.

Students enrolled in this LHS course have the opportunity to register with Mid-State Technical College to receive Dual Credit. See pages 12-13 for details.



FOOD SCIENCE

Course: 920
Credit: .5
Grade: 11, 12
Prerequisite: None
Fee: \$15.00

If it's on the grocery store shelf, a food scientist was involved. This course will use a hands-on approach to learning about the work of a food scientist through food lab experiments. You will be able to test and sample edible food products. Learn the proper techniques used to conduct food research and the types of equipment used to test the chemical properties of food. Apply the stages of food product development to create and package a new food. Investigate the many career opportunities related to food science and deepen your understanding of nutrition. Explore current issues in food science, food safety, and food production. Participate in a field trip to learn more about the food industry. This course supports career choices in food technology, nutrition and dietetics, food science, family and consumer sciences, and food chemistry.

EC

This is a science equivalency course. Successful completion will count toward .5 credit of science. See pages 14 for details.

FAMILY & CONSUMER SCIENCES

CULINARY ARTS

PRO. COOKING I (PROSTART I)

Course: 926
Credit: .5
Grade: 10, 11, 12
Prerequisite: None
Fee: \$15.00

Learn to work and cook like a pro. Develop teamwork skills through restaurant simulations, in-school catering and culinary challenges. Get trained in proper knife techniques, using equipment in a commercial kitchen, and practice basic cooking methods. Make homemade soups, sauces, bake desserts, and prepare pasta, potatoes, fruits, and vegetables with creative flair. Participate in a restaurant field trip. Examine current trends in the restaurant industry and develop menus and ideas for new restaurant concepts. Students will explore career pathways in hospitality, tourism, and food service management through the ProStart curriculum designed by the National Restaurant Association.

Pro. Cooking I and Pro. Cooking II may be taken concurrently.



PRO. COOKING II (PROSTART II)

Course: 928
Credit: .5
Grade: 11, 12
Prerequisite: Pro. Cooking I
Fee: \$15.00

Master the techniques to take your cooking and baking skills to the next level. Use creative talents and skills to cook and plate food professionally. Create cakes and specialty desserts. Prepare breakfast foods, meat, and seafood. Construct sandwiches, salads, and learn strategies to cook healthful, tasty, and nutrient-rich menu items. Strengthen teamwork skills through restaurant simulations, advanced catering labs and culinary challenges. Participate in a restaurant field trip and new learn culinary techniques from guest speakers. This class is a continuation of the ProStart curriculum designed by the National Restaurant Association.

Pro. Cooking I and Pro. Cooking II may be taken concurrently.



Students enrolled in this LHS course have the opportunity to register with Mid-State Technical College Sanitation for Foodservice Operations to receive Dual Credit and become Serv Safe certified. See pages 12-13 for details.

BAKING AND PASTRY

Course: 925
Credit: .5
Grade: 10, 11, 12
Prerequisite: None
Fee: \$15.00

Explore the art of baking. Demonstrate creativity with a variety of recipes and bakeshop ingredients. Develop pastry chef skills to make bread, pastries, quick breads, scones, cookies, specialty desserts, and cakes. Labs will focus on food safety, culinary skills, teamwork, and employability skills. Projects include community service baking, creating and marketing a new product, mastering the art of service, individual and team baking challenges. This class is a continuation of the ProStart curriculum designed by the National Restaurant Association.

Baking and Pastry and Pro. Cooking may be taken concurrently.



FAMILY & CONSUMER SCIENCES

Family & Consumer Sciences

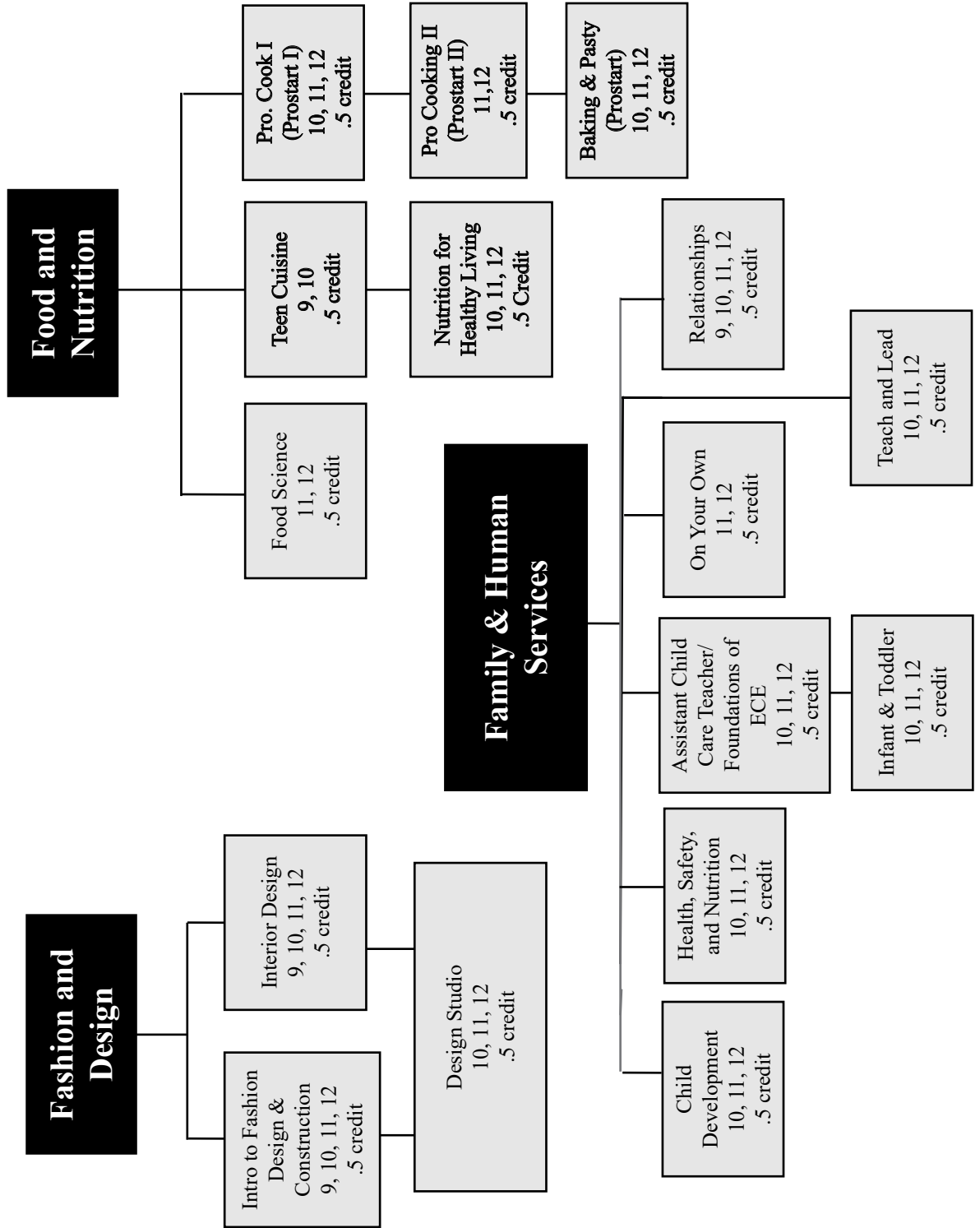

HEALTH EDUCATION AND HEALTH SCIENCE



Courses Required For Graduation From This Department: 0.5 credit Health Education

HEALTH EDUCATION

Course: 895
Credit: .5
Grade: 9, 10, 11, 12
Prerequisite: None
Fee: None

This course is a comprehensive health education curriculum. It is designed to provide students with knowledge and skills that will have a positive, long term affect upon their health and the health of others, as well as consequences of behaviors that occur during adolescent years. The class is structured around physical, mental, emotional, and social tasks that students need to resolve in order to develop to their full health potential.

MENTAL WELLNESS AND STRESS MANAGEMENT

Course: 897
Credit: .5
Grade: 9, 10, 11, 12
Prerequisite: Health Education
Fee: None

This course is a comprehensive health education curriculum. It is designed to provide students with knowledge and skills that will have a positive, long term affect upon their health and the health of others, as well as consequences of behaviors that occur during adolescent years. The class is structured around physical, mental, emotional, and social tasks that students need to resolve in order to develop to their full health potential.

Students enrolled in this LHS course have the opportunity to register with Mid-State Technical College to receive Dual Credit. See pages 12-13 for details.



INTRO TO HEALTH SCIENCE

Course: 896
Credit: .5
Grade: 9, 10, 11, 12
Prerequisite: Health Education
Fee: None

Anyone planning to go on to college for a career in health care or medicine should take Introduction to Health Science. This is the introductory course for all courses in the Health Science program at Lincoln High School. Students will study the important topics of safety and infection control; learn about the importance of communication in a health care setting with an introduction to medical terminology; explore the history of health care, and understand the importance of confidentiality and HIPAA.

HEALTH SCIENCE FOUNDATIONS

Course: 350
Credit: .5
Grade: 10, 11, 12
Prerequisite: Intro to Health Science
Fee: \$35.00 for CPR certification. No waiver allowed.

This course explores the various life stages of human development from the social, mental/emotional and physical aspects. Introduction to advanced directives, medical math, and vital signs will also be studied. Students will gain leadership skills as well as certification in First Aid and CPR/AED for the Professional Rescuer/Health Care Provider through the American Red Cross. HOSA: Future Health Professionals activities will be integrated throughout the curriculum.

HEALTH EDUCATION AND HEALTH SCIENCE

MEDICAL OCCUPATIONS EXPLORATION

Course: 352
Credit: .5
Grade: 10,11, 12
Prerequisite: Intro to Health Science
Fee: None

There is a whole world of opportunities waiting for you in health care! This course gives students the opportunity to discover a wide range of careers in the health care industry. Information regarding health care career clusters and health care careers, body systems, body planes and cavities as well as. Student will also have an overview of the laws and ethics to help provide competent, compassionate care to patients that is within acceptable legal and ethical boundaries. HOSA: Future Health Professionals activities will be integrated throughout the curriculum.

NURSING ASSISTANT FOUNDATIONS

Course: 351
Credit: .5 LHS
.75 SCN - LHS (3 MSTC)
Grade: 11, 12
Prerequisite: Intro to Health Science
Fee: See course description

Students considering taking the Nursing Assistant Foundations class will be expected to enroll in MSTC's **evening** Nursing Assistant course that begins in January/February of the current school year. The LHS Nursing Assistant Foundations class will work in conjunction with MSTC's Nursing Assistant evening course. Therefore, students will take both the LHS Nursing Assistant Foundations class and the MSTC Nursing Assistant course receiving transcribed credit for both classes. Students will learn basic nursing skills, personal care skills, basic restorative skills, clients' rights, and how to care for residents with dementia. Once students have completed both courses and the certification test, they will be qualified to work as a Certified Nursing Assistant. Additional units in employability will be taught which will address resume building, interviewing techniques and job applications and professionalism.

Students will need to purchase scrubs, the workbook (approximately \$25) and other equipment.



Students will need to provide their own transportation to the evening MSTC Nursing Assistant portion of the course. Students must be 16 years of age to take the certification test.

MEDICAL TERMINOLOGY

Course: 355.5
Credit: 1.0
Grade: 11, 12
Prerequisite: None
Fee: Approximately \$80.00. Cost is determined by cost of MSTC textbook each year. No waiver allowed.

Students focus on the component parts of medical terms: prefixes, suffixes and word roots. Students will practice formation, analysis, and reconstruction of terms. Emphasis is placed on spelling, definition, and pronunciation. This is an introduction to operative, diagnostic, therapeutic, and symptomatic terminology of all body systems as well as systemic and surgical terminology.

There may be a limited number of seats available in this course.

Students enrolled in this LHS course have the opportunity to register with Mid-State Technical College to receive Dual Credit. See pages 12-13 for details.



HEALTH EDUCATION AND HEALTH SCIENCE

Central Cities Health Institute Designation

During the Externship rotations, the students will experience the daily activities of a wide variety of health care professionals in our community. Some careers they may experience include: veterinary, dental, physical therapy, assisted living/memory care, pharmacy, imaging, chiropractor, occupational therapy, medical assistant, optometry, dietician, social work, laboratory, and nursing. Students who are interested in participating in the Medical Occupations Externship during their senior year **MUST** successfully complete **FOUR** of the health science courses for consideration in this class.

Students will also receive the Central Cities Health Institute (CCHI) designation by their name in the graduation program when they complete the Externship course.

MEDICAL OCCUPATIONS EXTERNSHIP

Course: 356
Credit: .5
Grade: 12
Prerequisite: See course description
Fee: None

Students will be involved in three 4-week externship experiences in local health care settings. The students will have on-the-job training and participate in health care skill development evaluated by their site manager and the classroom teacher. Classroom activities will include online portfolio development and health care skill preparation. This will allow students to gain workplace experience in several of the careers that they studied throughout their health science education. **Students will need to have their own transportation to worksites.**

This class is for 12th graders who have taken any four of the classes listed below after they complete Health Education. Students must apply for this class through instructor. Selection is based on attendance, skills, employability, attitude, personality, and successful completion of the application process. Students must be up to date with their vaccines to be placed at most of the medical sites. **There are a limited number of seats available in this course.**

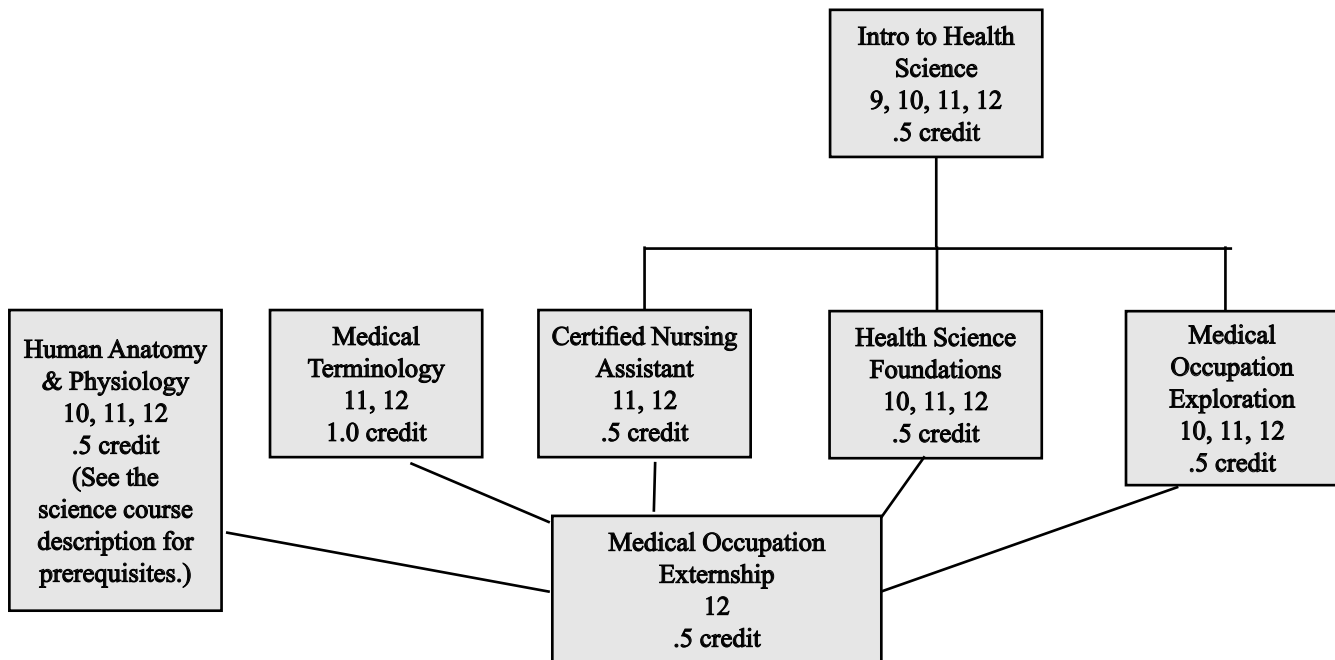

MATHEMATICS



Courses Required For Graduation From This Department: 3 Credits

Four credits of math-- Algebra 1, Geometry, Algebra 2 and Pre-Calculus-- are strongly encouraged for students who plan to attend a four-year college or university.

EXTENDED ALGEBRA 1

Course: 407
Credit: 1.5
Grade: 9
Prerequisite: Math 8
Fee: None

Teacher Recommendation is required for registration in Extended Algebra 1.

Extended Algebra 1 is a math course for ninth-grade students who would benefit from the integration of additional skill growth and practice time throughout the algebra curriculum. As in Algebra 1, students will study families of functions with special emphasis given to linear and quadratic functions. As each family of functions is studied, the student will learn to represent them in multiple ways - as verbal descriptions, as equations, as tables, and as graphs. The students will also learn to model real-world situations using functions in order to solve problems arising from those situations. Extra time will be spent reteaching and reinforcing basic skills needed to fully understand the Algebra curriculum.

ALGEBRA 1

Course: 406
Credit: 1.0
Grade: 9, 10, 11, 12
Prerequisite: Math 8
Fee: None

The content of Algebra 1 is organized around families of functions, with special emphasis given to linear and quadratic functions. As each family of functions is studied, the student will learn to represent them in multiple ways-- as verbal descriptions, as equations, as tables, and as graphs. The student will also learn to model real-world situations using functions in order to solve problems arising from those situations. In addition to this algebraic content, Algebra 1 includes lessons on probability and data analysis as well as numerous examples involving geometry.

A scientific calculator is required for this course. In Algebra 2 a TI-83 or TI-84 graphing calculator will be required.



GEOMETRY

Course: 415
Credit: 1.0
Grade: 9, 10, 11, 12
Prerequisite: Passing grade in each term of Algebra 1
Fee: None

Geometry emphasizes reasoning and logical thinking and balances coordinate and plane geometry with transformational geometry and solid geometry. The student will study and practice the concept of proof using a variety of methods. The student will also seek understanding of geometric concepts through construction, incorporating technology as a problem-solving tool. The student will connect geometry to algebra, data analysis, probability, and trigonometry.

A scientific calculator is required for this course. In Algebra 2 a TI-83 or TI-84 graphing calculator will be required.

8th grade students must earn a B or better all 3 terms of Algebra 1 to take Geometry in 9th grade.



MATHEMATICS

ACCELERATED GEOMETRY

Course: 416
Credit: 1.0
Grade: 9, 10, 11, 12
Prerequisite: Passing grade in each term of Algebra 1
Fee: None

Accelerated Geometry covers all of the topics from Geometry, but does so with more detail and more complex problems. Less time will be spent reviewing previously learned material with more emphasis placed on new concepts. In addition, this course will cover a few topics that are not covered in Geometry. Accelerated Geometry is recommended for students who plan to pursue college degrees in math-related fields and/or students with high ability and strong interest in mathematics.

A scientific calculator is required for this course, however a TI-83 or TI-84 graphing calculator is recommended.

(Not open to those students who have taken Geometry - 415.)



8th grade students must earn a B or better all 3 terms of Algebra to take Accelerated Geometry in 9th grade.

ALGEBRA 2

Course: 409
Credit: 1.0
Grade: 10, 11, 12
Prerequisite: Minimum grade of C in each term of Algebra 1 and Geometry or completion of Int. Algebra
Fee: None

Algebra 2 is devoted to the study of advanced high school algebra topics. *This is a fast-paced course for those who intend to continue their education after high school.* The student will learn about linear, quadratic, exponential, polynomial, rational, and logarithmic functions; discrete mathematics; trigonometry; and probability. *Algebra 2 completes the 3-year **minimum** requirement for college admissions.*

A graphing calculator is required for this course. A TI-83 or TI-84 is recommended. A limited number of graphing calculators are available for rent through the math department.



ACCELERATED ALGEBRA 2

Course: 410
Credit: 1.0
Grade: 10, 11, 12
Prerequisite: Minimum grade of C in each term of Algebra 1 and Geometry or completion of Int. Algebra
Fee: None

Accelerated Algebra 2 covers all of the topics from Algebra 2, but does so with more detail and more complex problems. Less time will be spent reviewing previously learned material with more emphasis placed on new concepts. In addition, this course will cover a few topics that are not covered in Algebra 2. Accelerated Algebra 2 is recommended for students who plan to pursue college degrees in mathematics, engineering, science or computer science and/or students with high ability in math who are planning to take Calculus at some point.

A graphing calculator is required for this course. A TI-83 or TI-84 is recommended. A limited number of graphing calculators are available for rent through the math department.

(Not open to those students who have taken Algebra 2 - 409.)



MATHEMATICS

AP PRE-CALCULUS

Course: 413
Credit: 1.0
Grade: 11, 12
Prerequisite: Minimum grade of C in each term of Algebra 2
Fee: None



AP Pre-calculus is a college-prep course which covers all of the topics covered in a typical Pre-calculus course but in greater depth. The course is recommended for students who plan to pursue college degrees in mathematics, engineering, science or computer science and/or students with high ability in math who are planning to take Calculus at some point. This course may also be appropriate for seniors seeking college math credit while in high school.

A graphing calculator is REQUIRED for this course. You must have your own calculator to take this course. A TI-83 or TI-84 is recommended.

Students choosing to take the AP exam will be charged approximately \$95.00. The cost of the AP exam is determined by the College Board.

INTRODUCTION TO STATISTICS

Course: 426
Credit: .5
Grade: 11, 12
Prerequisite: Passing grade in each term of Algebra 1, exposure to both parts of Geometry
Fee: None

Introduction to Statistics, a junior-senior elective, will provide students with a background in basic statistics and probability concepts while reinforcing and maintaining basic algebra skills. Using hands-on activities, students will investigate event probabilities and will predict outcomes based on these probabilities. Students will learn how to accurately collect and represent data in different ways and how to describe different shapes of data distributions. Students will learn how to interpret data displays found in the real world and learn how to analyze data found in these displays. Emphasis will be placed on hands-on activities and real-world applications.

This course is not intended for students who wish to earn college credit in Statistics.

COLLEGE PREP MATH

Course: 428
Credit: 1.0
Grade: 11, 12
Prerequisite: Minimum grade of C in each term of Algebra 2
Fee: None

College Prep Math is a fourth-year college preparatory mathematics course for students whose intended college program of studies does not require calculus. The algebra and functions units review and extend their ability to recognize, represent and solve problems involving relations among quantitative variables. Key families of functions that are focused on are linear, exponential, power, polynomial, logarithmic, and circular functions sine and cosine. The statistics and probability units develop students' ability to summarize, represent, and interpret categorical data, to recognize and measure variation, to review and apply basic probability concepts, and to understand binomial distributions and how they are used for statistical inference. The discrete mathematics units develop students' quantitative literacy and problem-solving ability related to fundamental aspects of contemporary life.

EXPLORATIONS IN ALGEBRA AND GEOMETRY

Course: 419
Credit: .5
Grade: 11, 12
Prerequisite: Passing grade in each term of Algebra 1, exposure to both parts of Geometry
Fee: None

Teacher recommendation is required for registration in Explorations in Algebra & Geometry.

Explorations in Algebra and Geometry, a junior-senior elective, will provide the math student the opportunity to re-visit topics from Algebra and Geometry. The course will emphasize mastery in basic skills and exposure to real-life applications as well as preparation for standardized tests.

Explorations is not intended for students who plan to attend a four-year college immediately after high school and is not intended for students who have passed Algebra 2, Intermediate Algebra or higher.

MATHEMATICS

FINANCIAL ALGEBRA

Course: 421
Credit: 1.0
Grade: 11, 12
Prerequisite: Two credits of high school math
Fee: None

Financial Algebra, a junior-senior elective, is designed to meet the Wisconsin State Financial Literacy Standards by focusing on the mathematical skills and concepts associated with these standards. Students will learn how math can be used in their lives as they learn the “mathematics of money.” Specific topics will include money management; credit and debt management; planning, saving, and investing; relating income and education; becoming a critical consumer; community and financial responsibility; and risk management.

This course satisfies the Financial Literacy graduation requirement.

It is not recommended that students take this class if they have already taken On Your Own or Personal Finance. Not open to those students who will be taking or have taken Intermediate Algebra or Algebra 2.

ACCELERATED FINANCIAL ALGEBRA

Course: 422
Credit: .5
Grade: 11, 12
Prerequisite: Concurrent or past enrollment in Intermediate Algebra or Algebra 2
Fee: None

Accelerated Financial Algebra, a junior-senior elective, is a condensed version of Financial Algebra that is intended for students who plan to continue their education beyond high school. Not only will this course meet the Wisconsin State Financial Literacy Standards but it will also review concepts taught in Algebra 2/Intermediate Algebra. Students will learn how math can be used in their lives as they learn the “mathematics of money.” Specific topics will include money management; credit and debt management; planning, saving, and investing; relating income and education; becoming a critical consumer; community and financial responsibility; and risk management as well as functions, solving and graphing equations, basic data and statistics, and the use of various formulas.

This course satisfies the Financial Literacy graduation requirement.

(Not open to those students who have taken Financial Algebra - 421.)



INTERMEDIATE ALGEBRA

Course: 420.5
Credit: 1.0
Grade: 11, 12
Prerequisite: Passing grades in Algebra 1 & Geometry OR both semesters of Explorations
Fee: None

Intermediate Algebra, a junior-senior elective, aligns with the Mid-State Technical College Intermediate Algebra with Application course, their entry-level college algebra course. Students enrolling in a Wisconsin Technical College System school after graduation will need Intermediate Algebra (or Algebra 2) for entry into most programs. Topics in Intermediate Algebra include properties of real numbers, order of operations and evaluating expressions, algebraic solutions to linear equations, inequalities, and systems, algebraic solutions to quadratic and radical equations, operations with polynomial and rational expressions, rational exponents, and radicals, linear, quadratic, exponential, and logarithmic functions, and right triangle trigonometry. Students will also study the properties of graphs of functions and relations as well as the inverses of these functions.

Intermediate Algebra is not an option for students who have been successful in Algebra 2 or higher unless they have teacher permission.

Students enrolled in this LHS course have the opportunity to register with Mid-State Technical College to receive Dual Credit. See pages 11-12 for details.



APPLIED MATH FOR THE TRADES

Course: 418
Credit: .5
Grade: 11, 12
Prerequisite: See course description
Fee: None

Applied Math for the Trades is a junior/senior level elective math course that is designed to benefit students that are interested in a CTE pathway and the Trades. Emphasis on specific mathematical applications used in the LHS Manufacturing and Welding courses will be learned with hands-on lessons and projects. Students pursuing a degree in Machine Tool or Welding will benefit from this math class being dual-credit with MSTC as this course will satisfy the math requirement for those programs.

Passing grades in Algebra 1 and Geometry is required. It is STRONGLY recommended that this course be taken prior to or concurrently with enrollment in a CTE pathway course.

Students enrolled in this LHS course have the opportunity to register with Mid-State Technical College to receive Dual Credit. See pages 11-12 for details.



MATHEMATICS

AP STATISTICS

Course: 427
Credit: 1.0
Grade: 11, 12
Prerequisite: Minimum grade of B in each term of Algebra 2 or teacher recommendation

AP Statistics, a college-level statistics course, is an Advanced Placement course offering open to motivated students in Grade 11 or Grade 12 who have successfully completed Algebra 2. AP Stats is approximately equivalent to a one-semester college statistics course, which is typically required for college majors such as social sciences, health sciences, business, and education. Students are exposed to four broad conceptual themes: Exploring Data, Planning a Study, Anticipating Patterns, and Statistical Inference. Students are expected to take the AP exam in May and may earn college credit. Note: *It is recommended that students take AP Statistics along with another math class; AP Statistics may not fulfill a high school math credit requirement for some universities where statistics is a separate department from mathematics.*

Fee: None

A graphing calculator is REQUIRED for this course. You must have your own calculator to take this course. A TI-83 or TI-84 is recommended.

Students choosing to take the AP exam will be charged approximately \$95.00. The cost of the AP exam is determined by the College Board.



AP CALCULUS AB

Course: 423
Credit: 1.0
Grade: 12
Prerequisite: Minimum grade of B in each term of Precalculus
Fee: None

AP Calculus AB, a college-level course that follows the four-year high school math program, consists of work in calculus comparable to that of a first semester course in Calculus at the college or university level. **This class will be challenging and time-consuming and it is an expectation that students will spend time outside of class to be successful.** It is expected that students who take AP Calculus AB will seek credit or placement, or both, from institutions of higher learning. *Students taking this class are expected to have a full knowledge of all Precalculus topics including, but not limited to, fractions, factoring, functions, algebraic manipulation and trigonometry.* Topics learned in Calculus will be limits, derivatives and integrals. The Advanced Placement test in Calculus will be given in early May, and those students who choose to take it may earn college credit if they pass the test. Note: Students are **NOT** required to take calculus in high school as a prerequisite for college mathematics.

Students choosing to take the AP exam will be charged approximately \$95.00. The cost of the AP exam is determined by the College Board.



Student registered for AP Calculus AB will receive a Pre-Course Skills Review Packet. This packet consists of problems that review math skills covered in previous math classes. It is an expectation that students work on these problems prior to the course beginning and demonstrate proficiency in these areas by the time they begin the course. Students will be tested on this material during the first week of the course.

AP CALCULUS BC

Course: 425
Credit: 1.5
Grade: 12
Prerequisite: Minimum grade of B in each term of Precalculus
Fee: None

AP Calculus BC, a college-level course that follows the four-year high school math program, is comparable to that of a first and second semester course in Calculus at the college or university level. **This class will be challenging and time-consuming, and it is an expectation that students will spend time outside of class to be successful.** It is expected that students who take AP Calculus BC will seek credit or placement, or both, from institutions of higher learning. *Students taking this class are expected to have a full knowledge of all Precalculus topics including, but not limited to, fractions, factoring, functions, algebraic manipulation and trigonometry.* Topics learned in Calculus will be limits, derivatives, integrals, sequences and series, parametric equations and vector equations. Note: Students are **NOT** required to take calculus in high school as a prerequisite for college mathematics.

The Advanced Placement test in Calculus will be given in early May and is required of those students who choose to take Calculus BC. Students may earn college credit if they pass the test. Students will need to pay for the AP exam and will be charged approximately \$95.00. The cost of the AP exam is determined by the College Board.



Students registering for AP Calculus BC will receive a Pre-Course Skills Review Packet. This packet consists of problems that review math skills covered in previous math classes. It is an expectation that students work on these problems over the summer and demonstrate proficiency in these areas by the time they return in the fall. Students will be tested on this material during the first week of school.

MATH

Heading to the Workforce/Maybe Technical College

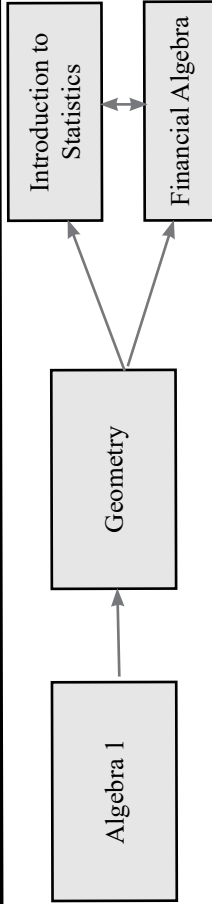

Heading to a Technical College

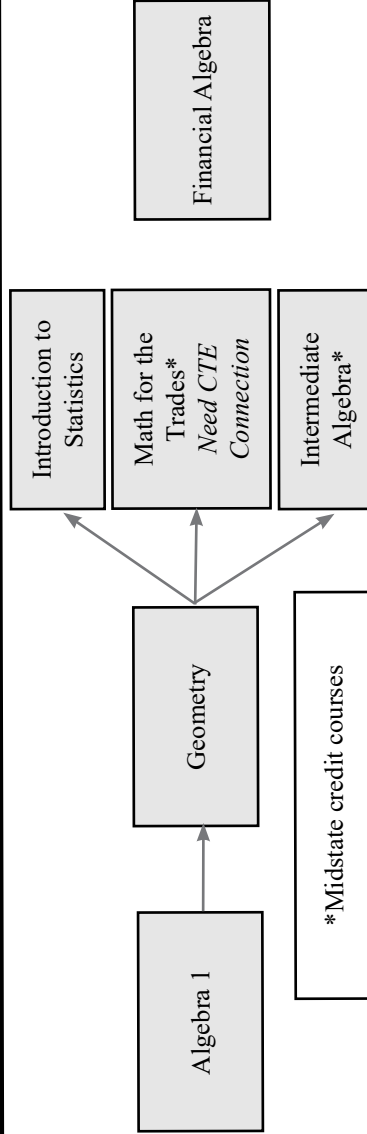

Heading to a 4-Year University - Not Accelerated

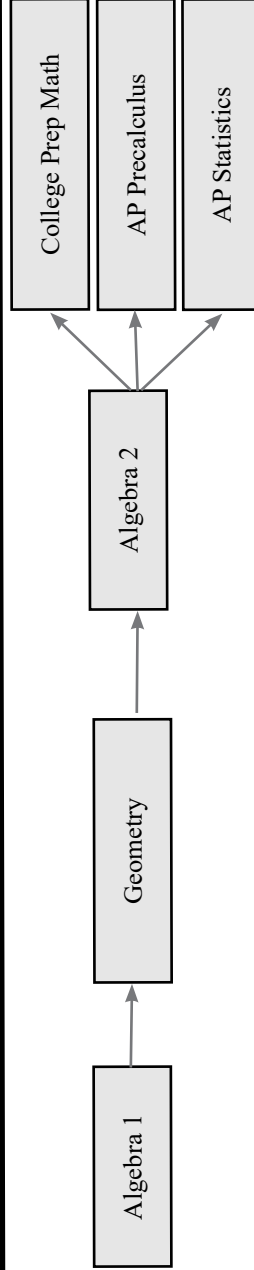

Heading to a 4-Year University - Accelerated

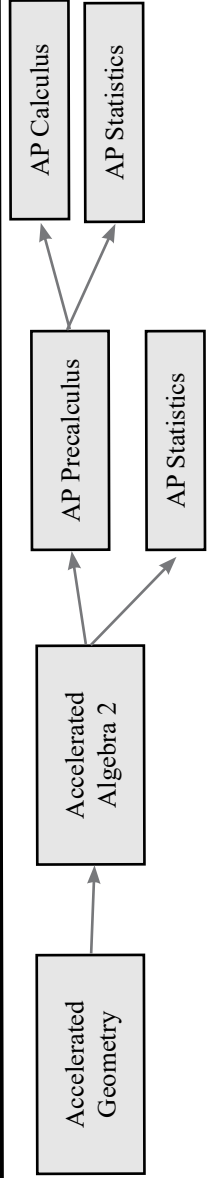

MUSIC



Courses Required For Graduation From This Department: None

BAND 9

Course: 650
Credit: 1.5
Grade: 9
Prerequisite: Band 8
Fee: None

Band 9 is offered to all students with previous experience on a traditional band instrument. Skills and concepts from the previous year are developed and expanded upon. In addition to continued refinement of individual performance skills, greater emphasis is placed on ensemble performance skills. Students will continue to develop their knowledge of music theory, begin to analyze and evaluate music, and use critical thinking skills to make refinements in their performance.

1st Trimester all students participate in Marching Band - there is a required camp scheduled in August (before school starts)

Concert attendance is required, and a grade is assigned to concert attendance.

Students are required to wear black for most concerts.

CONCERT BAND

Course: 656
Credit: 1.5
Grade: 10, 11, 12
Prerequisite: Band 9
Fee: None

Concert Band is offered to all students with previous experience on a traditional band instrument. Continued emphasis is given to the development of musicianship and basic skills through a large repertoire of appropriate level band literature. Involvement in this course will acquaint students with many of the life skills necessary to be successful in the workplace including personal relations, problem solving and working as a team to produce a product.

1st Trimester all students participate in Marching Band - there is a required camp scheduled in August (before school starts)

Concert attendance is required, and a grade is assigned to concert attendance.

Students are required to wear black for most concerts.

WIND ENSEMBLE

Course: 653
Credit: 1.5
Grade: 10, 11, 12
Prerequisite: Audition
Fee: None

Wind Ensemble is comprised of a select group of instrumental music students who thrive on the challenge of difficult wind literature. Students work towards mastering the concepts and skills in rich tone quality, group and individual intonation, expressing appropriate style for various time periods, advanced articulations, and fluid technique. Precision in music reading is expected. Involvement in this course will acquaint students with many of the life skills necessary to be successful in the workplace including personal relations, problem solving and working as a team to produce a product.

Participation in a large group for Solo and Ensemble Festival is required.

1st Trimester all students participate in Marching Band - there is a required camp scheduled in August (before school starts)

Concert attendance is required, and a grade is assigned to concert attendance.

Students are required to wear black for most concerts.

ORCHESTRA 9

Course: 660
Credit: 1.5
Grade: 9
Prerequisite: Orchestra 8
Fee: None

Orchestra 9 is offered to all students with previous experience in orchestra (violin, viola, cello, bass) or students who wish to learn a stringed instrument. Emphasis is placed on developing musical independence through the study of challenging, yet exciting repertoire. Ninth grade orchestra students will learn basic music theory, vibrato and how to peg-tune. They will have an opportunity to join the following co-curricular activities: Chamber Players, Mariachi Band, Fiddle Squad, Pit Orchestra, and Solo and Ensemble Festival.

Participation in a large group for Solo and Ensemble Festival is required.

Concert attendance is required, and a grade is assigned to concert attendance.

Students are required to wear all black for most concerts.

MUSIC

STRING ORCHESTRA

Course: 664
Credit: 1.5
Grade: 10
Prerequisite: Orchestra 9
Fee: None

String Orchestra is intended for all 10th grade string students who have completed Orchestra 9. In String Orchestra, an emphasis is placed on developing independent playing through an ensemble experience. Students will be introduced to advanced position work through string-only repertoire that will challenge and inspire them. Co-curricular groups offered with String Orchestra membership include Chamber Players, Mariachi Band, Pit Orchestra, Fiddle Squad, and participation in Solo and Ensemble Festival.

Participation in a large ensemble for Solo and Ensemble Festival is required.

Concert attendance is required, and a grade is assigned to concert attendance. Students are required to wear all black for most concerts.

SYMPHONY ORCHESTRA

Course: 663
Credit: 1.5
Grade: 11, 12
Prerequisite: Orchestra 9
Fee: None

Symphony orchestra is offered to junior and senior students of violin, viola, cello, and double bass. The main emphasis of the class is to gain a thorough understanding of string and full orchestra techniques and literature. Students will continue to refine their skills, while introducing new time signatures, advanced position work, and repertoire. Co-curricula groups offered with Symphony membership include: Chamber Players, Fiddle Squad, Mariachi Band, Pit Orchestra, and Solo & Ensemble Fest.

Concert attendance is required, and a grade is assigned to concert attendance. Students are required to wear all black for most concerts.

CHOIR 9

Course: 670
Credit: 1.5
Grade: 9
Prerequisite: None
Fee: None

This choir is open to any 9th Grade student who likes to sing and wants to strengthen their music skills. Emphasis is placed on rhythmic and melodic reading skills as well as healthy vocal production. Students will continue to grow as a musician individually as well as being a strong ensemble member. Solo and ensemble participation is encouraged and strengthens music preparation and performance skills. This choir sings music of many various styles and performs at concerts.

Participation in all concerts is required.

Co-curricular opportunities include: A Cappella Choir, Bass Clef Choir, Treble Clef Choir, Chamber Singers, Vocal Jazz, Spring Musical and Solo and Ensemble Festival.

BEL CANTO CHORUS

Course: 673
Credit: 1.5
Grade: 10, 11, 12
Prerequisite: Teacher Recommendation
Fee: None

This choir is open to all treble voices who have completed at least one year of choir or by teacher recommendation. Bel Canto will explore a wide range of music written for treble choir. Singers will continue to develop their music reading, vocal production and performance skills. Participation in solo and ensemble festival is encouraged to enhance student growth and achievement. This choir performs at concerts, as well as occasional area performances.

Participation in all performances is required.

Co-curricular opportunities include: A Cappella Choir, Bass Clef Choir, Treble Clef Choir, Chamber Singers, Vocal Jazz, Spring Musical and Solo and Ensemble Festival.

LHS MIXED CHOIR

Course: 676
Credit: 1.5
Grade: 10, 11, 12
Prerequisite: None
Fee: None

This choir is open to soprano, alto, tenor and bass voices. Singers will continue to develop their music reading, vocal production and performance skills while singing a wide variety of music and styles. Participation in solo and ensemble festival is encouraged to enhance student growth and achievement. This choir performs at concerts.

Attendance at concerts is required.

Co-curricular opportunities include: A Cappella Choir, Bass Cleff Choir, Treble Clef Choir, Chamber Singers, Vocal Jazz, Spring Musical and Solo and Ensemble Festival.

MUSIC

AMERICA'S MUSIC HISTORY

Course: 682
Credit: .5
Grade: 9, 10, 11, 12
Prerequisite: None
Fee: None

America's Music History explores genres including folk, country, blues, rock, and hip hop. There will be a lot of listening, reading, and note-taking, along with projects and assessments in this class. You do NOT need to be in band, orchestra, or choir to take this class.

MUSIC HISTORY AND LITERATURE

Course: 684
Credit: .5
Grade: 10, 11, 12
Prerequisite: None
Fee: None

This course is designed to give students an understanding of what we call "classical" music starting with the Middle Ages and ending with modern art music. This is geared toward students who love classical music, like taking notes, doing projects, and doing a lot of listening while honing their listening skills.



RAIDER RHYTHM

Course: 683
Credit: .5
Grade: 9, 10, 11, 12
Prerequisite: None
Fee: None

This general music course provides a rich, appropriate, high-quality, meaningful musical experience for students. All students are valued and recognized for their strengths and learn to help and support each other through learning about music. Students learn to create, respond to, and perform music through multi-sensory means: singing, listening, word response, sound response, hand instruments, drumming, dance, and more.

MUSIC THEORY

Course: 686
Credit: .5
Grade: 10, 11, 12
Prerequisite: None
Fee: None

Music Theory is designed to expose students to basic music notation, rhythmic notation, time signatures, and key signatures. Students will also develop listening skills and aural training (i.e. hear what is written) to be able to identify basic rhythms, melodies, intervals, and chords. More complex aspects of the musical language will be introduced, such as time signatures, minor scales, transposition, two-part harmony, basic triads and choral harmonies. Aural skills and ear training will be further developed through rhythmic and melodic examples, as well as the introduction of sight singing. Related concepts will be introduced to build upon the students' vocabulary.

Music Theory is a prerequisite for AP Music Theory.

AP MUSIC THEORY

Course: 685
Credit: .5
Grade: 10, 11, 12
Prerequisite: Music Theory
Fee: None

AP Music Theory is a rigorous study of music theory for students interested in pursuing music beyond high school. The focus will be on skills required to be successful as a first year music student at a college, university or conservatory. The course is designed to prepare students for the AP music theory test in the spring. Students considering this class should have a strong background in music, including the ability to read both bass and treble clefs fluently. Course content will include harmony and harmonic analysis, melodic and rhythmic structure, part-writing, formal analysis, score reading, and a music history overview. Personal musical skills will be developed daily through ear-training, dictation and sight singing. Although keyboard skills are not required, they are beneficial and should be developed during the term of the class.

Students choosing to take the AP exam will be charged approximately \$95.00. The cost of the AP exam is determined by the College Board.



MUSIC TECHNOLOGY

Course: 687
Credit: .5
Grade: 10, 11, 12
Prerequisite: None
Fee: None

This course is project-based in the study of digital notation, sound production, and recording. Students will focus on several aspects of music technology including on-line music notation software and current sound technologies. Students will also learn the ins and outs of making professional recordings in a studio setting.

PHYSICAL EDUCATION



Courses Required For Graduation From This Department: 1.5 Credits

Physical Education I and 1 additional credit are required.
It is recommended that students complete their physical education requirement by their junior year.

PHYSICAL EDUCATION I

Course: 881
Credit: .5
Grade: 9
Prerequisite: None
Fee: None

All ninth grade physical education classes are co-ed. Activities in physical education for the ninth grade will be: football, games (large and small groups), speedway, basketball, volleyball, softball, weight training, rhythm/dance, fitness, floor hockey, badminton, and tennis. There will be a weekly emphasis on an aerobic workout.

PHYSICAL EDUCATION II

Course: 882
Credit: .5
Grade: 10, 11
Prerequisite: PE I
Fee: None

Emphasis will be placed on being in the Healthy Fitness Zone (fitness-gram). Students will achieve/strive to be in the Healthy Fitness Zone through workouts as well as learning and playing team sports. The sports which promote personal and social relationships include (but are not limited to): flag/touch football, soccer, softball, ultimate frisbee, tennis, pickleball, raiderball, basketball, volleyball, bukaball, swimming, intro to physical fitness, and strength training.

MOBILITY, FITNESS & NUTRITION

Course: 885
Credit: .5
Grade: 10, 11, 12
Prerequisite: Instructor/
counselor
approved
Fee: None

This course will emphasize movement and fitness concepts that some young adults struggle with. It will be a course that prepares students to be more physically active, gain a better self-image and continue to improve their fitness level. We will also explore nutrition and the benefits of clean eating.

This course requires counselor and teacher recommendation and can be taken more than once with **instructor approval**.

INDIVIDUAL & DUAL LIFETIME

Course: 883
Credit: .5
Grade: 10, 11, 12
Prerequisite: PE I
Fee: \$15.00

Students will develop an understanding of the skills and strategies involved in a choice of individual and dual sports. A variety of lifetime sports are offered within the curriculum to enhance the student's self-concept and personal well-being. Activities for Individual & Dual Lifetime in trimesters 1 and 3 include tennis, archery, golf, pickleball, badminton, pool games, self defense, curling, bowling, and broomball. Activities for Individual & Dual Lifetime in trimester 2 include cross country skiing, curling, badminton, pickleball, table tennis, pool games, bowling, broomball, biathlon, snowshoe, self-defense and softball.

Fee applies to in-class bowling, and curling and self-defense field trips.

PHYSICAL EDUCATION

STRENGTH CONDITIONING AND FITNESS

Course: 884
Credit: .5
Grade: 10, 11, 12
Prerequisite: PE I
Fee: None

This course will emphasize the general principles of fitness. Students will be given the opportunity to improve their general physical preparedness (GPP) by working within the 10 Physical Skills: cardiovascular, stamina, strength, flexibility, power, speed, coordination, agility, balance & accuracy. Students will also be exposed to sport-specific preparation (SPP) by creating individualized strength programs. **Out of class time will be expected.**

(May be repeated with instructor approval.)

STRENGTH CONDITIONING AND FITNESS (BLENDED)

Course: 884.1
Credit: .5
Grade: 12
Prerequisite: PE I
Fee: None

This course will cover the same material as the current Strength & Fitness course, however the daily requirement to attend would not be expected. There will be certain required days of the week for physical attendance, as well as finding time to schedule one-on-one time with the instructor, but 2-3 days each week students will accomplish the curriculum using activities approved by the instructor and documented through in an online format (website). These will be opportunities for students to workout on their own time and document what they have done online. Formative grading will be online while the summative portion of the grade will need to be accomplished in front of the instructor either in one-on-one, small group, or regularly scheduled class period.

WIAA REFEREE CERTIFICATION

Course: 893
Credit: .5
Grade: 11, 12
Prerequisite: PE I
Fee: None

This course will cover many basics of officiating and rules of the games. Students will have the ability to become WIAA registered officials in a variety of sports including, but not limited to: soccer, basketball, volleyball, baseball, softball & football. The course will also explore a variety of leadership and coaching principles related to practice planning, tactics, player development, and philosophy.

Do you have on-the-spot decision making skills, self-confidence, the dedication and determination necessary to work hard, and personal integrity? Consider becoming a certified WIAA referee! Learn the rules of the sports you're interested in and the ins-and-outs of officiating, with the goal of preparing yourself to earn the license required for the world of working as a WIAA referee.

TRIATHLON/AEROBICS-TRAINING

Course: 886
Credit: .5
Grade: 11, 12
Prerequisite: PE I
Fee: None

Students will take part in a triathlon training program that includes swimming, biking, and running and concludes with a "sprint triathlon" competition. Students will also be given the opportunity to improve their cardiovascular endurance plus shape and tone their bodies through aerobic activities such as: tae bo, step, Pilates, hip-hop, P-90X and more.

LIFE RESPONDERS

Course: 892
Credit: .5
Grade: 11, 12
Prerequisite: PE I
Fee: \$110.00

This course is designed to teach and certify students in First Aid, Professional Rescuer CPR, Lifeguarding and WSI (Water Safety Instruction). Students who successfully complete this course can be certified as lifeguards and swimming instructors based on the guidelines of the American Red Cross. This class has an online and in-class component; successful completion of both is required for certification.

Advanced Swimming skills are required to take this class. Continuous swimming of 300 yards, 2 minutes of treading water, and knowledge of the 4 competitive strokes, side stroke, and elementary backstroke is necessary. The 2nd day of class will test out prerequisite skills.

PHYSICAL EDUCATION

OUTDOOR EDUCATION F/S

Course: 890FS
Credit: .5
Grade: 12
Prerequisite: PE I
Fee: \$30.00

This course will emphasize group cooperation and improved mental, physical, and emotional conditioning through the exploration of team building and outdoor pursuits. This course uses experiential education to integrate previous listed concepts into the following units: Canoeing, Rock Climbing/Rappelling, Snorkeling/Scuba, High Ropes Course, Initiative Tasks, Biking, Broomball. Course fees are utilized for field trip opportunities and maintenance of our specialized equipment.

All students interested in this course will need to have an informed consent form on file with the physical education department prior to registration.

Students cannot take this course if they have already taken Environmental Lit. in the Outdoors. Students should have a proficient level of fitness. This course is offered in trimesters 1 and 3.

WINTER OUTDOOR EDUCATION

Course: 890W
Credit: .5
Grade: 12
Prerequisite: PE I
Fee: \$30.00

This course will emphasize group cooperation and improved mental, physical, and emotional conditioning through the exploration of team building and outdoor pursuits. This course uses experiential education to integrate previous listed concepts into the following units: Indoor Rock Climbing/Rappelling, Snorkeling/Scuba, High Ropes Course, Initiative Tasks, Orienteering, Snowshoeing, Broomball, Cross Country Skiing, Curling. Course fees are utilized for field trip opportunities and maintenance of our specialized equipment.

All students interested in this course will need to have an informed consent form on file with the physical education teacher prior to registration.

Students cannot take this course if they have already taken Environmental Lit. in the Outdoors. Students should have a proficient level of fitness. This course is offered in trimester 2.

ENVIRONMENTAL LITERATURE IN THE OUTDOORS

Course: 891, 120
Credit: 1.0 (.5 P.E. & .5 ELA)
Grade: 11, 12
Prerequisite: PE I
Fee: None

This is a junior-senior level, team-taught, two-trimester class. This course combines the curriculum ideas from the English class Environmental Literature with the curriculum of the Physical Education class Outdoor Education. It meets for one class period for two trimesters with students receiving .5 ELA credit for one trimester and .5 Physical Education for one trimester. The class blends the themes of survival and current environmental topics studies in fiction and non-fiction with the physical activities associated with them (including but not limited to rock climbing, high ropes course, fishing, survival shelters, cross-country skiing, foraging, etc.) as well as evaluating factors that impact safety and promoting positive decision making. The composition component of the course will help students make connections between the literature while explaining the technical skills associated with adventure and outdoor pursuits.

All students interested in this course will need to have an informed consent form on file with the physical education teacher prior to registration.

Students will receive a .5 English credit and a .5 Physical Education credit for this course.

SPORTS CHALLENGE

Course: 888
Credit: .5
Grade: 12
Prerequisite: PE I
Fee: None

Sports Challenge includes advanced skill development in a variety of activities. A number of highly competitive tournaments and contests will take place. Individual game strategies and officiating skills will be explored and demonstrated. Activities include tennis, lacrosse, flag football, softball, ultimate, soccer, basketball, volleyball, floor hockey, pool games, badminton, broomball, dodgeball, table tennis, pickleball.

There will be a high emphasis on competition and effort.

SCIENCE



Courses Required for Graduation From This Department: 3 Credits

***1 credit of science should be completed in both 9th and 10th grade.**

It is recommended that students take at least one class in all 5 categories (Biology, Chemistry, Physics, Earth, and Environmental) for a well rounded knowledge base.

OBJECTIVES: The science program will provide students the opportunity to:

- discover science rather than learn only facts
- become scientifically literate
- develop the ability to live harmoniously with nature
- understand the processes of science

BIOLOGY

MACROBIOLOGY

Course: 324
Credit: .5
Grade: 9, 10, 11, 12
Prerequisite: See description
Fee: \$10.00



This inquiry based course is designed for students who are interested in the study of living organisms and need to take science courses to meet graduation or college entrance requirements. Students will learn the major characteristics of organisms in each of the currently recognized Kingdoms by studying representatives of each of the Kingdoms. Students will observe, grow, and dissect various organisms. The course also investigates natural systems and cycles - the ways living things are interconnected and interact with each other. This course is a hands on approach to science education that stresses inquiry. Methods of study will involve lab work, experimentation, lecture, projects, dissection, and discussion.

We recommend that if you are considering Macrobiology as an incoming freshman, that you talk with your 8th grade science teacher and get their opinion on whether they feel you are ready for the rigors of Macrobiology.

MICROBIOLOGY

Course: 315
Credit: .5
Grade: 10, 11, 12
Prerequisite: None
Fee: \$10.00



This inquiry based course is designed for students who are interested in the study of living organisms at the cellular level. It includes detailed study of complex topics and is essential for students considering a career in Biology related fields such as health care and medical science, environmental science, nutrition and food science, and others. Students will investigate the structure of cells and functions of cell organelles; along with DNA, genetics, and inheritance, and the evolution of life on Earth. This course is a hands-on approach to science education that stresses inquiry. Methods of study will involve lab work, lecture, projects, and discussion.

This course is a prerequisite for Biotechnology Explorations and recommended for Principles of Biomedical Science.

HUMAN ANATOMY & PHYSIOLOGY

Course: 326
Credit: .5
Grade: 10, 11, 12
Prerequisite: None
Fee: \$10.00



This biology course is designed for students who are interested in learning about the structure and function of the human body. Through lab, lecture, projects, and discussion based activities students will study the various organ systems of their bodies. They will learn the location and names of muscles, bones and organs. The physiology of organ systems will be studied to discover the proper functioning of each system, with an emphasis on making healthy lifestyle choices. Independent projects and vertebrate dissections are an integral part of the course.

SCIENCE

PRINCIPLES OF BIOMEDICAL SCIENCE (PLTW)

Course: 344
Credit: 1.0
Grade: 10, 11, 12
Prerequisite: C or better in last science class, or instructor consent. Microbiology recommended
Fee: \$15.00

This course is part of the Project Lead The Way (PLTW) Biomedical Science program. It is a rigorous, fast-paced class where students explore concepts of biology and medicine as they take on roles of different biomedical professionals to solve real-world problems. Over the course of two trimesters, students are challenged in various scenarios including investigating a crime scene to solve a mystery, diagnosing and proposing treatment to patients in a family medical practice, tracking down and containing a medical outbreak at a local hospital, stabilizing a patient during an emergency and collaborating with others to design solutions to local and global medical problems. The activities introduce students to forensic science, genetics, human physiology, medicine, microbiology, and public health. This is an advanced course for students seriously interested in a career in healthcare.

Some colleges award credit for this class based on scores on a national end of course exam.



HUMAN BODY SYSTEMS (PLTW)

Course: 329
Credit: 1.0
Grade: 10, 11, 12
Prerequisite: Earn a grade of C or better in their last science course or instructor consent.
Fee: \$15.00

Students examine the interactions of body systems as they explore the identity, communication, power, movement, protection, and homeostasis of the human body. Students will design experiments, investigate the structures and functions of the human body through a number of dissections, and use data collection software to monitor body functions such as muscle movement, reflex and voluntary action, and respiration. Exploring science in action, students build organs and tissues on a skeletal manikin, work through interesting real world cases and often play the role of bio-medical professionals to solve medical mysteries. This is an advanced course for students seriously interested in the medical field and/or the human body.

Some colleges award credit for this class based on scores on a national end of course exam.



BIOTECHNOLOGY EXPLORATIONS

Course: 328
Credit: .5
Grade: 10, 11, 12
Prerequisite: Microbiology
Fee: \$15.00

In this exciting biology course students will discover the structure of the DNA molecule and current technology associated with DNA: in forensics, agriculture, medicine, and industry. Specific lab activities include genetic modification of bacteria to make them glow in UV light, DNA fingerprinting, amplification of students' DNA by PCR, testing of corn products to determine genetic modification, current understanding of cancer and its genetic origins, and investigation of stem cell research. Ethical considerations of the use of biotechnology will be investigated. This is a lab-based course that also includes lecture, discussion, modeling, internet research, use of technology, and group projects.



PHYSICS

CONCEPTUAL PHYSICS

Course: 308
Credit: .5
Grade: 9, 10, 11, 12
Prerequisite: None
Fee: None

Conceptual Physics is a laboratory course that covers topics in motion, forces, momentum, energy, waves, and light. The course focuses on concepts, as students will use reasoning and problem-solving skills. The math related to this course focuses on basic arithmetic with simple algebra and will be reinforced throughout the course. The focus will be to gain a better descriptive understanding of the world around them by applying physics concepts.



SCIENCE

PHYSICS: FORCE AND MOTION

Course: 340
Credit: .5
Grade: 10, 11, 12
Prerequisite: Geometry
Fee: None

The way things move have fascinated society for centuries. This highly hands on class studies movement from various aspects. Topics studied will include measurement, one and two dimensional motion, forces, momentum, and energy. These essential topics of physics are covered using laboratory experiments, problem solving, collaboration, and discussion. The emphasis is on the descriptive aspects of physics, but concepts will be reinforced through problem solving.

Physics: Force and Motion is not a prerequisite of General Physics 1, however it may be taken before General Physics 1. Students who have passed General Physics 1 cannot take Physics- Force and Motion.

***NOTE:** If you'd like to receive UWSP credit (optional) you need to register for and take Physics 101 (Course #353) in your junior or senior year.



PHYSICS: FORMS OF ENERGY

Course: 341
Credit: .5
Grade: 10, 11, 12
Prerequisite: Geometry
Fee: None

Energy is a key part of society. This hands on class will study energy in its most essential forms. Topics studied will include measurement, waves, sound, light, heat, electricity and magnetism. These essential topics of physics are covered using laboratory experiments and classroom materials. The emphasis is on the descriptive aspects of physics, but concepts will be reinforced through problem solving.

Physics: Forms of Energy is not a prerequisite of General Physics 1, however it may be taken before General Physics 1. Students who have passed General Physics 1 cannot take Physics - Forms of Energy.

***NOTE:** If you'd like to receive UWSP credit (optional) you need to register for and take Physics 101 (Course #353) in your junior or senior year.



PHYSICS 101

Course: 353
Credit: 1.0 LHS credit
 5.0 UWSP credits
Grade: 11, 12
Prerequisite: Geometry and UWSP enrollment
Fee: Approximately \$495

Physics 101 is a concurrent enrollment course with UW-Stevens Point. Physics 101 is a natural science elective course designed for college students seeking degrees in liberal arts, elementary education, general education, communicative disorders, nursing, medical support (not doctors), physical education and non-science majors. Physics 101 combines Physics: Force and Motion with Physics: Forms of Energy in the same school year with an independent study unit for UWSP credit.

Students taking this course must sign up for concurrent enrollment credit. See page 14 for further details.

Physics 101 cannot be taken after Physics-Forms of Energy or Physics-Force and Motion or General Physics 1.



GENERAL PHYSICS 1

Course: 345.5
Credit: 1.0 LHS credit
 4.0 MSTC credits
Grade: 11, 12
Prerequisite: Enrollment/ completion of Algebra 2 or Intermediate Algebra or higher or instructor consent
Fee: None

General Physics 1 is a FREE dual enrollment course with Mid-State Technical college that transfers to all of the UW system campuses and many out of state and private universities. General Physics 1 presents the applications and theory of basic physics principles. This course emphasizes problem solving, laboratory investigation, and applications. Topics include unit conversion and analysis, vectors, translational and rotational kinematics, translational and rotational dynamics, heat and temperature, and harmonic motion and waves. Students who wish to take the AP Physics 1 exam can still do so, but note, additional study and preparation on your own will be required. This is a great class for students who are looking to work in any of the natural sciences, engineering or engineering technology, natural resources and medicine or veterinary science.

Students choosing to take the AP exam will be charged approximately \$95.00. The cost of the AP exam is determined by the College Board.

Students enrolled in this LHS course have the opportunity to register with Mid-State Technical College to receive Dual Credit. See pages 12-13 for details.



SCIENCE

ENVIRONMENTAL

ENVIRONMENTAL SCIENCE 1

Course: 312
Credit: .5
Grade: 9, 10, 11, 12
Prerequisite: None
Fee: None

This course will explore ecological and environmental science concepts. This course includes inquiry based components. During ecosystems study, specific topics of study are biomes/ecosystems, transfer of energy/food webs, populations, natural cycles, and human impacts on the environment. Methods of study include lecture, in-class and outdoor labs, discussions, projects, and use of classroom materials and technology.



ENVIRONMENTAL SCIENCE 2

Course: 320
Credit: .5
Grade: 10, 11, 12
Prerequisite: Environmental
Science 1
Fee: \$10.00

This upper-level hands-on course will give the student an opportunity to further their understanding of our environment through in-depth study. Students will study the scientific principles, concepts, and methodologies required to understand the interrelationships of the natural world. They will identify and analyze environmental problems both natural and human-made. Extensive class time will be held outside doing laboratory exercises and students will need to have taken Environmental Science 1.



AP ENVIRONMENTAL SCIENCE

Course: 323
Credit: .5
Grade: 10, 11, 12
Prerequisite: Environmental
Science 2
Fee: \$10.00

AP Environmental Science is designed to be the equivalent of a one semester, introductory college course in environmental science and specifically intended for those students who intend to take the college Board AP Environmental Science exam in May. (There will be a cost for this exam) This course will provide students with the scientific principles, concepts, and methodologies required to understand the interrelationships of the natural world, to identify and analyze environmental problems both natural and human made, to evaluate the relative risks associated with these problems, and to examine alternative solutions for resolving and/or preventing them.

Students choosing to take the AP exam will be charged approximately \$95.00. The cost of the AP exam is determined by the College Board.



CHEMISTRY

CHEMISTRY 1

Course: 333
Credit: .5
Grade: 9, 10, 11, 12
Prerequisite: None
Fee: None

This course is the introductory offering in the sequence of chemistry courses offered at LHS.

Chemistry 1 is the study of matter and topics covered will include atomic structure, the periodic table, writing and naming chemical formulas, chemical bonding, a survey of chemical reactions, and the states of matter. Successful completion of Chemistry 1 prepares the student for entry into Chemistry 2. Methods of study will include laboratory work, modeling activities, guided inquiry, lectures, and discussion.



CHEMISTRY 2

Course: 330
Credit: .5
Grade: 10, 11, 12
Prerequisite: Chemistry 1 and
Algebra 1
Fee: \$10.00

This course will continue the study of chemistry that was started in Chemistry 1. This course is designed for students who need to take an additional science course to meet graduation or college entrance requirements, and also for students who desire to take AP Chemistry or Chemistry 3. Chemistry is the study of matter. Topics studied will include chemical compounds, chemical quantities, chemical equations, water and solutions, molecular structure and intermolecular forces. Methods of study will include laboratory work, lecture and discussion.

A scientific calculator is recommended for this class.



SCIENCE

CHEMISTRY 3

Course: 332
Credit: .5
Grade: 10, 11, 12
Prerequisite: Chemistry 2
Fee: \$10.00

This course will continue the study of chemistry that was started in Chemistry 2. This course is designed for students who need to take an additional science course to meet graduation or college entrance requirements. Topics studied will include the behavior of gases, thermochemistry, electrochemistry, acid-base reactions, and equilibrium. These essential topics of chemistry are covered using laboratory experiments and classroom materials.

A scientific calculator is recommended for class.



AP CHEMISTRY

Course: 331
Credit: 1.0
Grade: 10, 11, 12
Prerequisite: Chemistry 2
Fee: \$10.00

AP Chemistry is designed to be the equivalent of a general chemistry course taken during the first year of college. Topics such as the structure of matter, kinetic theory of gases, chemical equilibria, chemical kinetics, and the basic concepts of thermodynamics will be covered in considerable depth. Students will engage in laboratory work that challenges their abilities to think clearly and to express their ideas with clarity and logic including an emphasis on chemical calculations and the mathematical formulation of principles.

Students choosing to take the AP exam will be charged approximately \$95.00. The cost of the AP exam is determined by the College Board.

There is a summer assignment for this class. Students will complete one unit and complete problems and exercises related to this unit. There will be a test on the summer work the first two weeks of school.



EARTH SCIENCE

EARTH STRUCTURE & PROCESSES

Course: 309
Credit: .5
Grade: 9, 10, 11, 12
Prerequisite: None
Fee: None

Earth Structure and Process is an introductory course in earth sciences. Students will learn about how scientists study earth and the processes that happen around us. Topics will include earth's interior layers, plate tectonics and its impacts, and factors that influence weather and climate. Students will learn what we know about earth and how we know it.



ASTRONOMY

Course: 327
Credit: .5
Grade: 10, 11, 12
Prerequisite: Algebra 1
Fee: None

Students will explore the universe and earth's place in it along with the scientific processes that we use to understand it. Students will learn about the development of models that improved our understanding of the broader universe. Topics will include the formation, scale, and structure of our solar system, stars, galaxies, and the greater universe. This course will help students with an interest in Astronomy meet graduation requirements and college entrance requirements.



PHYSICAL GEOLOGY

Course: 336
Credit: .5
Grade: 10, 11, 12
Prerequisite: Earth Structure and Processes
Fee: \$10.00

Through studying properties of minerals, the formation of rocks, weathering and erosion, and plate tectonics, students will gain an understanding of why the Earth's surface looks the way that it does. Students will use their understanding of geological processes to explore the history of landforms in Central Wisconsin. This course will help students with an interest in Earth Science meet graduation and college entrance requirements.



SCIENCE

METEOROLOGY, OCEANOGRAPHY, AND CLIMATOLOGY

Course: 338
Credit: .5
Grade: 10, 11, 12
Prerequisite: Earth Structure
and Processes
Fee: None

Students will explore the characteristics of the atmosphere and the oceans and investigate the processes that influence weather and climate. Major topics will include physical and chemical properties of the oceans, weather patterns that affect Central Wisconsin and North America, and worldwide climate patterns and their causes. Students will use tools of meteorologists to understand local weather, and historical and current climate data to investigate patterns of climate change. This course will help students with an interest in Earth Science meet graduation and college entrance requirements.



INTERDISCIPLINARY

TOPICS IN LIFE SCIENCE

Course: 313
Credit: .5
Grade: 9, 10
Prerequisite: None
Fee: None

Students will learn about cells, DNA, genetics, organisms, evolution, and ecology through the exploration of real life phenomena such as cancer, albinism, dog breeds, cicadas, parasites, and/or animals in Africa. Lessons are driven by student questions as they interact with each phenomenon. Students will use science skills to explore their topics, analyze data, develop models and come up with answers to their own questions and explanations for the phenomena. Active participation by the student in the investigation of topics is required in order to successfully complete this course.

TOPICS IN PHYSICAL SCIENCE

Course: 314
Credit: .5
Grade: 9, 10
Prerequisite: None
Fee: None

Students will learn about chemistry, physics, and earth science through the exploration of real life phenomena such as sounds, extreme weather, collisions, and how cell phones work. Lessons are driven by student questions as they interact with each phenomenon. Students will use science skills to explore their topics, analyze data, develop models, and come up with answers to their own questions and explanations for the phenomena. Active participation by the student in the investigation of topics is required in order to successfully complete this course.

LIFE SCIENCES AND SOCIETY

Course: 342
Credit: .5
Grade: 11, 12
Prerequisite: None
Fee: None

This is a project-based course in which students explore current issues confronting society from a scientific perspective. Emphasis will be placed on critical thinking skills, research, and evidence-based decision making. Topics may include but are not limited to: current advances in biotechnology, food safety, plastics in the environment, emerging pathogens, global population trends, human health issues, loss of biodiversity, and others as determined by the instructor. The goal of this class to increase science literacy and empower students to use scientific reasoning and critical thinking skills to gain reliable information, solve problems and make sound decisions in their own lives.



*This is a non-lab based course, students planning to attend college should take the course as credits beyond the 3 required in natural science.

PHYSICAL SCIENCES AND SOCIETY

Course: 343
Credit: .5
Grade: 11, 12
Prerequisite: None
Fee: None

This is a project-based course in which students explore current issues confronting society from a scientific perspective. Emphasis will be placed on critical thinking skills, research, and evidence-based decision making. Topics may include but are not limited to: water & air quality, depletion of resources, global climate change, exploring space, meeting energy needs, nanotechnology and others as determined by the teacher. The goal of this class to increase science literacy and empower students to use scientific reasoning and critical thinking skills to gain reliable information, solve problems and make sound decisions in their own lives.



*This is a non-lab based course, students planning to attend college should take the course as credits beyond the 3 required in natural science.

Science

SCIENCE

Biology

Macrobiology
 9, 10, 11, 12
 .5 credit

 Microbiology
 10, 11, 12
 .5 credit

 Human Anatomy & Physiology
 10, 11, 12
 .5 credit

 Principles of Biomedical Science
 (PLTW)
 10, 11, 12
 1.0 credit

 Human Body Systems (PLTW)
 10, 11, 12
 1.0 credit

 Biotechnology Explorations
 10, 11, 12
 .5 credit

Physics

Conceptual Physics
 9, 10, 11, 12
 .5 credit

 Physics 101 A-Force and
 Motion
 10, 11, 12
 .5 credit

 Physics 101 B -Forms of
 Energy
 10, 11, 12
 .5 credit

 Physics 101
 11, 12
 1.0 credit

 General Physics 1
 11, 12
 1.0 credit

Environmental

Environmental Science 1
 9, 10, 11, 12
 .5 credit

 Environmental Science 2
 10, 11, 12
 .5 credit

 AP Environmental Science
 10, 11, 12
 .5 credit

Chemistry

Chemistry 1
 9, 10, 11, 12
 .5 credit

 Chemistry 2
 10, 11, 12
 .5 credit

 Chemistry 3
 10, 11, 12
 .5 credit

 AP Chemistry
 10, 11, 12
 1.0 credit

Earth Science

Earth Structure & Processes
 9, 10, 11, 12
 .5 credit

 Physical Geology
 10, 11, 12
 .5 credit

 Astronomy
 10, 11, 12
 .5 credit

 Meteorology, Oceanography,
 and Climatology
 10, 11, 12
 .5 credit

Interdisciplinary

Topics in Life Science
 9, 10
 .5 credit

 Life Sciences and Society
 11, 12
 .5 credit

 Topics in Physical Science
 9, 10
 .5 credit

 Physical Science and Society
 11, 12
 .5 credit

Note: This is not a flow chart. Each box contains a list of science course offerings within a science category. Please refer to the science department program pages for course descriptions. If you have a specific career pathway in mind we encourage you to discuss your options with your school counselor or a science teacher. Please also refer to page 6 for technical and four year college information.

*1 credit of science should be completed in both 9th and 10th grade.

SOCIAL STUDIES



Courses Required For Graduation From This Department: 3 Credits

Human Geography or AP Human Geography- 1 Credit
Contemporary American History, AP United States History, or America's Voice & America's Story- 1 Credit
American Government, Constitutional Law, or AP American Government- .5 Credit
Social Studies Electives - 1/2 Credit

HUMAN GEOGRAPHY

Course: 200
Credit: 1.0
Grade: 9
Prerequisite: None
Fee: None



In Human Geography A, students will explore the unique environments in which people around the world live and how those environments shape an individual group's way of life. After investigating topics, such as world population, resource availability, folk and popular culture, world religion, and race and ethnic constructs, students will have a broad understanding of the forces shaping our current world. In Human Geography B, students will explore the development of countries and forces shaping countries today. After investigating topics, such as political organization, the global community, global economic development, and land use and food production, students will have a broad understanding of the forces shaping our current world. Additionally, there will be a special emphasis on the development of social studies disciplinary skills; students will have ample opportunity to complete inquiry projects, take positions and propose solutions to modern issues, and participate in debates and simulations.

AP HUMAN GEOGRAPHY

Course: 260
Credit: 1.0
Grade: 9
Prerequisite: None
Fee: None



Human Geography is a course connecting human patterns of interaction to the world around you. This course provides students with an opportunity to expand their knowledge of our world from a broad, geographical perspective. Students will realize and appreciate the complexities of globalization and think critically about what they see, read, and hear about their world through critical analysis of culture, society and space. Students are challenged to think geographically across scale and across a wide range of geographical phenomena and global issues. Topics of study may include population, migration, geography of identity, agriculture, industry, city planning, and environmental challenges, among others.

This Advanced Placement course requires considerable reading, writing, critical thinking and application of concepts and theories.

(Not open to students who have taken Human Geography)

Students choosing to take the AP exam will be charged approximately \$95.00. The cost of the AP exam is determined by the College Board.

CONTEMPORARY AMERICAN HISTORY

Course: 210
Credit: 1.0
Grade: 10
Prerequisite: None
Fee: None



This course focuses on the 20th and 21st centuries where students will analyze America's role as a world power and explore the continuing development of our institutions. In addition to traditional social studies skills and objectives, students will also approach the study of American history through the arts, geography, primary documents, and literature. By connecting past events to present situations, students will develop a baseline for appraising modern problems. The requirement for American History can also be met by taking America's Voice/America's Story or AP American History.

(Not open to those students who have taken AP US History or America's Story/America's Voice.)

SOCIAL STUDIES

AMERICA'S STORY

Course: 211, 114
Credit: .5
Grade: 10
Prerequisite: None
Fee: None



America's Story is a sophomore level class that fulfills the American History (B) requirement which covers American history from the end of WW II until the present day. This course is the compliment to those students that took America's Voice. There will be a detailed analysis of the major historical figures and events that shaped America's political, social, and economic institutions. The use of novels, biographies, short stories, speeches, letters and a host of other primary sources will be used to teach the curriculum. Students will engage in the study of the curriculum through discussions, role plays, historical simulations, and a host of other hands-on activities. There will be traditional multiple choice and short answer tests, however the primary means of assessment will be through essays, Document Based Questions, historical research papers and other writing assignments.

Not open to those students who have taken American History or AP United States History.

AMERICA'S VOICE-SOCIAL STUDIES

Course: 214, 114
Credit: .5
Grade: 10
Prerequisite: None
Fee: None



America's Voice is a sophomore level, team-taught, two-trimester class. This course will combine the curriculum ideas from English II A with the curriculum time periods from Contemporary American History A. It meets for one class period for two trimesters with students receiving .5 ELA credit for trimester 1 and .5 Social Studies for trimester 2. The class blends American history with America's literary tradition. Students will study the issues in our past (beginning in 1900 through World War II) and will read literature associated with each period. Much of the learning is discussion-based and emphasis is placed on both analyzing literature (novels, short stories and poetry) and writing essays. The course is team-taught by a social studies teacher and a language arts teacher.

Not open to those students who have taken American History or AP United States History.

AP UNITED STATES HISTORY

Course: 257
Credit: 1.0
Grade: 10
Prerequisite: None
Fee: None



AP United States History is a two term course that integrates political, social, economic, cultural, diplomatic, and intellectual history in order to convey the experiences of particular groups within the broader perspective of the American past. At the same time, it connects events and issues from the past to the concerns of the present. As students study the history, they will encounter the unexpected, unique events, unintended outcomes, and singular individuals that shaped America. It is a very rigorous course that follows the AP College Board guidelines and demands heavy reading and writing. The course is for those students who want more intense study of American History than the traditional Contemporary American History class.

Not open to those students who have taken American History or America's Voice.



Students choosing to take the AP exam will be charged approximately \$95.00. The cost of the AP exam is determined by the College Board.

AMERICAN HISTORY IN DEPTH

Course: 206
Credit: .5
Grade: 10, 11, 12
Prerequisite: None
Fee: None



Learn history by doing history. Want to choose your own research project? Want a chance to be creative with a topic that is important to you? Enjoy debatable topics? This seminar styled project based course allows students to conduct in depth explorations of specific themes in US history. By emphasizing research, projects, and writing, students will practice skills employed by professional historians including evaluating sources, analyzing and synthesizing information, and developing and proving a thesis. All of these skills will help prepare students for college as well as AP history exams. Students will also have an opportunity to compete in the National History Day competition. **This course is open to any student who has completed their American History requirement. It will always run the third trimester.**

Recommended for those who want to dive deeper into American History and those enrolling in AP US History. Students may take simultaneously with AP US History.

SOCIAL STUDIES

AMERICAN GOVERNMENT

Course: 201
Credit: .5
Grade: 11
Prerequisite: None
Fee: None

American Government is a study of the three levels of government and the branches within each level. The duties and functions of each level are emphasized with particular attention given to how they are separate, have unique responsibilities and yet work together. News sources are used to stimulate thought and discussion concerning government.

This course satisfies the government course required for graduation. Students cannot take this course if they have already taken Constitutional Law or AP Government and Politics.



AP GOVERNMENT & POLITICS

Course: 230
Credit: .5
Grade: 11
Prerequisite: None
Fee: None

American Government is a study of the three levels of government and the branches within each level. The duties and functions of each level are emphasized with particular attention given to how they are separate, have unique responsibilities and yet work together. This course engages students in a deep understanding of how government works, as well as, political beliefs and behavior. Critical thinking, group activities, and writing skills are stressed.

This course satisfies the government course required for graduation. Students cannot take this course if they have already taken American Government or Constitutional Law.



Students choosing to take the AP exam will be charged approximately \$95.00. The cost of the AP exam is determined by the College Board.

CONSTITUTIONAL LAW

Course: 255
Credit: .5
Grade: 11
Prerequisite: None
Fee: None

This course will begin with an in-depth study of the Constitution and the lawmaking process. Particular attention will be placed on the structure and content of the Constitution and the historical background that influenced the writing of this document. After learning about the foundations of our government, the course will then emphasize the Supreme Court and the role it plays in our political and legal systems. Students will learn how our government works by studying some of the most influential court cases in U.S. history. Students will display their understanding of the content through legal briefs, debates, mock trials, historical simulations, essays, and traditional exams.

This course satisfies the government course required for graduation. Students cannot take this course if they have already taken American Government or AP Government and Politics.



RUSSIA: CZARS, COMMUNISTS AND CONSPIRACIES

Course: 240
Credit: .5
Grade: 11, 12
Prerequisite: None
Fee: None

"Russia is a riddle wrapped in a mystery inside an enigma"- Winston Churchill. This course examines the mystery of Russia. As one of the world's great superpowers and the largest country on Earth, Russia continues to dominate its neighbors and influence world events. By studying its history and culture, students will discover the impact and power Russia still exerts. Beginning with the czars in the 16th century and ending with the modern day, students will analyze how history and tradition continue to shape modern Russia. Throughout the course students will use film, literature and primary sources to identify historical trends and events. Participation in simulations, debates, and discussions is expected.



CRIMINAL JUSTICE

Course: 229
Credit: .5
Grade: 11, 12
Prerequisite: None
Fee: None

Criminal Justice provides an overview of the complex system making up the criminal justice system. The course will explore the different types of crime in a society and the process taken from the time a crime takes place through the trial process. Students will study complex topics, such as the balance between individual rights and apprehending a criminal, and participate in several highly engaging activities, including a simulated crime scene investigation and a mock trial. Students will display their understanding of course content through interpretation of crime scene evidence, classroom and small group discussions, mock trials, and unit exams. This course is an elective and does not fulfill the American Government requirement.



SOCIAL STUDIES

PRINCIPLES OF ECONOMICS

Course: 222
Credit: .5
Grade: 11, 12
Prerequisite: None
Fee: None

Minimum wage, national debt, taxes, environmental destruction, high prices, health insurance, and unemployment are all current issues and they are all topics that will be discussed and debated in this course. The class will equip the student with basic economic literacy skills and a better understanding of current events. Topics studied include money creation and the banking system; international trade; the relationships among labor, business, and government; and personal finance. Students will be expected to participate in class simulations, activities, and discussions. Critical thinking and analysis are important skills that will be developed and strengthened in this course. Most of the assessment is based application/analysis of the course content and problem solving skills.

(Not open to those students who have taken AP Macroeconomics and AP Microeconomics.)

This course satisfies the Financial Literacy graduation requirement.



PRINCIPLES OF ECONOMICS (BLENDED INSTRUCTIONAL DELIVERY)

Course: 222.1
Credit: .5
Grade: 11, 12
Prerequisite: None
Fee: None

Minimum wage, national debt, taxes, high prices, health insurance, and unemployment are all current issues and they are all topics that will be discussed in this course. The class will equip the student with basic economic literacy skills and a better understanding of current events. Topics studied include money creation and the banking system; international trade; the relationships among labor, business, and government; and personal finance. Critical thinking and analysis are important skills that will be developed and strengthened in this course.

Students enrolled in this course will be taught using a blended format of online curriculum accompanied by some classroom instruction. The first week of the course will be taught in the classroom. After students become familiar with the course and the expectations, the class will move to an online format with students meeting a minimum of once a week in the classroom. Students enrolling in this course should expect to provide their own devices for the online requirements.

(Not open to those students who have taken AP Macroeconomics and AP Microeconomics.)

This course satisfies the Financial Literacy graduation requirement.



AP MACROECONOMICS

Course: 233
Credit: .5
Grade: 11, 12
Prerequisite: None
Fee: None

This course will run during the 2024-2025 school year. It will NOT run during the 2025-2026 school year.

Economics affects all of us, whether we understand it or not. So, why not increase your understanding? This course will provide insight into current political, economic, and global issues. You will be able to take what you learn in this class and apply it directly to current events. The course focuses on the basic economic principles of unemployment, inflation, investment, banking, taxes, debt, global trade, and economic growth. Various theories and viewpoints will be explored and discussed. The focus will be on critical thinking skills. Students will be asked to analyze situations, solve problems, weigh costs and benefits, predict outcomes, graph answers, and interpret those graphs. This course requires no essay writing. Students will be encouraged to take the Advanced Placement exam in May in order to earn college credit for the course.

Students choosing to take the AP exam will be charged approximately \$95.00. The cost of the AP exam is determined by the College Board.

This course satisfies the Financial Literacy graduation requirement.



AP MICROECONOMICS

Course: 234
Credit: .5
Grade: 11, 12
Prerequisite: None
Fee: None

This course will run during the 2025-2026 school year. It will NOT run during the 2024-2025 school year.

Microeconomics focuses on the behavior of individuals, industries, and business firms in making decisions regarding the allocation of scarce resources. Topics that will be covered include supply and demand, factors of production, profit, wages, monopoly, competition, pollution, minimum wage, welfare, and other government policies. Various theories and viewpoints will be explored and discussed. Students will be asked to analyze situations, solve problems, predict outcomes, graph answers, and interpret those graphs. The course requires no essay writing. Students are encouraged to take the Advanced Placement exam in May in order to earn college credit for the course.

Students choosing to take the AP exam will be charged approximately \$95.00. The cost of the AP exam is determined by the College Board.

This course satisfies the Financial Literacy graduation requirement.



SOCIAL STUDIES

TEACHING HISTORY THROUGH MEDIA

Course: 207
Credit: .5
Grade: 11, 12
Prerequisite: None
Fee: None

The goal of this class is to learn History through watching Hollywood movies. Each film will cover a specific time period or event in history. The class work will be divided into three different areas: The first area will be the introduction, as we will focus on events leading up to the time period and what the film is about. The second area will be the actual watching of the movie with discussion questions relating to the era or respective events. The third and final area will be the post work which may include discussion questions, work sheets, film reviews and/or review summaries.



PSYCHOLOGY

Course: 224
Credit: .5
Grade: 11, 12
Prerequisite: None
Fee: None

The course introduces students to the general principles of human behavior. The objective is for students to have a better understanding of themselves as we examine the major theories of psychology. Special attention is given to personality development, memory, altered states of consciousness, learning, perception, and abnormal behavior. Since Psychology is about ourselves, students will easily see the relevance of the topics to their lives.



AP PSYCHOLOGY

Course: 258
Credit: 1.0
Grade: 11, 12
Prerequisite: None
Fee: None

In AP Psychology, students will explore scientific study of human behavior and mental processes. The curriculum is very high-paced, which requires independent reading and writing, as well as critical thinking, class participation, and a high level of motivation. The class is taught like a college-level class in which students' knowledge is assessed primarily through tests, quizzes, primary readings and a final exam. Those not willing to make the commitment to AP level psychology are encouraged to take the Psychology course.

***There is summer work for this course.**

Students choosing to take the AP exam will be charged approximately \$95.00. The cost of the AP exam is determined by the College Board.



SOCIOLOGY

Course: 226.5
Credit: .5
Grade: 11, 12
Prerequisite: None
Fee: None

This is an elective course that introduces students to the basic concepts of sociology: culture, socialization, social stratification, and the five institutions of family, politics, economics, religion, and education. Other topics include demography, deviance, technology, environment, social issues, social change, and social organization. Class discussions, group activities, films, and written reflections will be used to analyze the importance of culture, apply Sociological perspectives, and summarize influences of socialization.

Students enrolled in this LHS course have the opportunity to register for Dual Credit awarded by Mid-State Technical College in related programs. This course may also be transferable to the university of your choice. See pages 12-13 and transfer information on page 14 for details.



CONTEMPORARY ISSUES

Course: 246
Credit: .5
Grade: 11, 12
Prerequisite: None
Fee: None

Interested in current events? This class is for you! Students will explore social, political, environmental, and economic issues of both the United States and the world in depth. Much of the learning in this course is project based which means that students will be active participants in the course from helping to plan the curriculum topics (with teacher discretion) to designing the projects students will be asked to complete. Possible topics that could be covered during the term include terrorism, current global conflicts, national debt, trade agreements, global warming, civil rights of minority groups, immigration, and much more. This course will integrate geography, culture, politics, and economics as we study issues from a variety of perspectives. Students will be expected to participate in classroom discussions, presentations, and debates. Critical thinking and analysis are important skills that will be developed and strengthened in this course.



SOCIAL STUDIES

INTRODUCTION TO DIVERSITY STUDIES

Course: 208.5
Credit: .5
Grade: 11, 12
Prerequisite: None
Fee: None

Introduction to Diversity Studies introduces learners to the study of diversity from a local to a global environment using a holistic, interdisciplinary approach. Encourages self-exploration and prepares the learner to work in a diverse environment. In addition to an analysis of majority/minority relations in a multicultural context, the primary topics of race, ethnicity, age, gender, class, sexual orientation, disability, and religion are explored. The instructional format for this course will vary between lectures, discussions, readings, individual and group projects, and educational videos.



Students enrolled in this LHS course have the opportunity to register for Dual Credit awarded by Mid-State Technical College in related programs. This course may also be transferable to the university of your choice. See pages 12-13 and transfer information on page 14 for details.



AP ART HISTORY

Course: 625, 225
Credit: 1.0
Grade: 11, 12
Prerequisite: None
Fee: None

AP Art History is an introductory college course in art history which includes the study of architecture, sculpture, painting, and other art forms within societal influences in history and culture. Students will critically analyze art and history starting with ancient civilizations through the 21st century modern works. No prior exposure to art history is required, however, students who have interest in humanities, such as history, literature and art, are encouraged to enroll. This course is team taught by a social studies teacher and an art teacher. Students passing the AP Exam may be eligible for college humanities credit.

Students will receive .5 Art credit and .5 Social Studies credit for AP Art History.



Students choosing to take the AP exam will be charged approximately \$95.00. The cost of the AP exam is determined by the College Board.



MODERN WORLD HISTORY OR HISTORY 102-WORLD HISTORY SINCE 1500

Course: 259 or 261
Credit: .5 LHS credit
3.0 UWSP credits
Grade: 11, 12
Prerequisite: None
Fee: See course description

In 1421, Admiral Zheng He from China navigated the largest fleet of ships the world has ever seen, the "Treasure Fleet," across much of the world. China was the global power. By 1842, Great Britain maneuvered its steamboats, unscathed, up Chinese rivers taking over cities with little resistance. How did such a drastic shift in the balance of power occur? In addition to answering questions like this, Modern World History/History 102 covers topics such as the Mongol Moment, The Demise of the Swahili Coast, Atlantic World Revolutions and their echos, the "Sick Man of Europe" Ottoman Empire, The Rise of Japan, and the World War Era including its aftermath. Activities such as simulations, projects, and traditional assessments will be used to assess student learning. Historical thinking skills like sourcing, comparing, and analyzing cause and effect will be emphasized in daily lessons.



At registration, students will be required to sign up for Modern World History (259) or History 102 (261) through UW-Stevens Point. The courses will run together and the content will the same, however, some assessments may differ.



History 102 - World History Since 1500 is a concurrent enrollment course through UW-Stevens Point. Students taking this course may sign up for concurrent enrollment credit. See page 14 for further details.

Regarding NCAA credit: Only History 102 (261) through UW-Stevens Point is currently approved through the NCAA. Course 259 is not approved through the NCAA at this time.

SOCIAL STUDIES

Social Studies

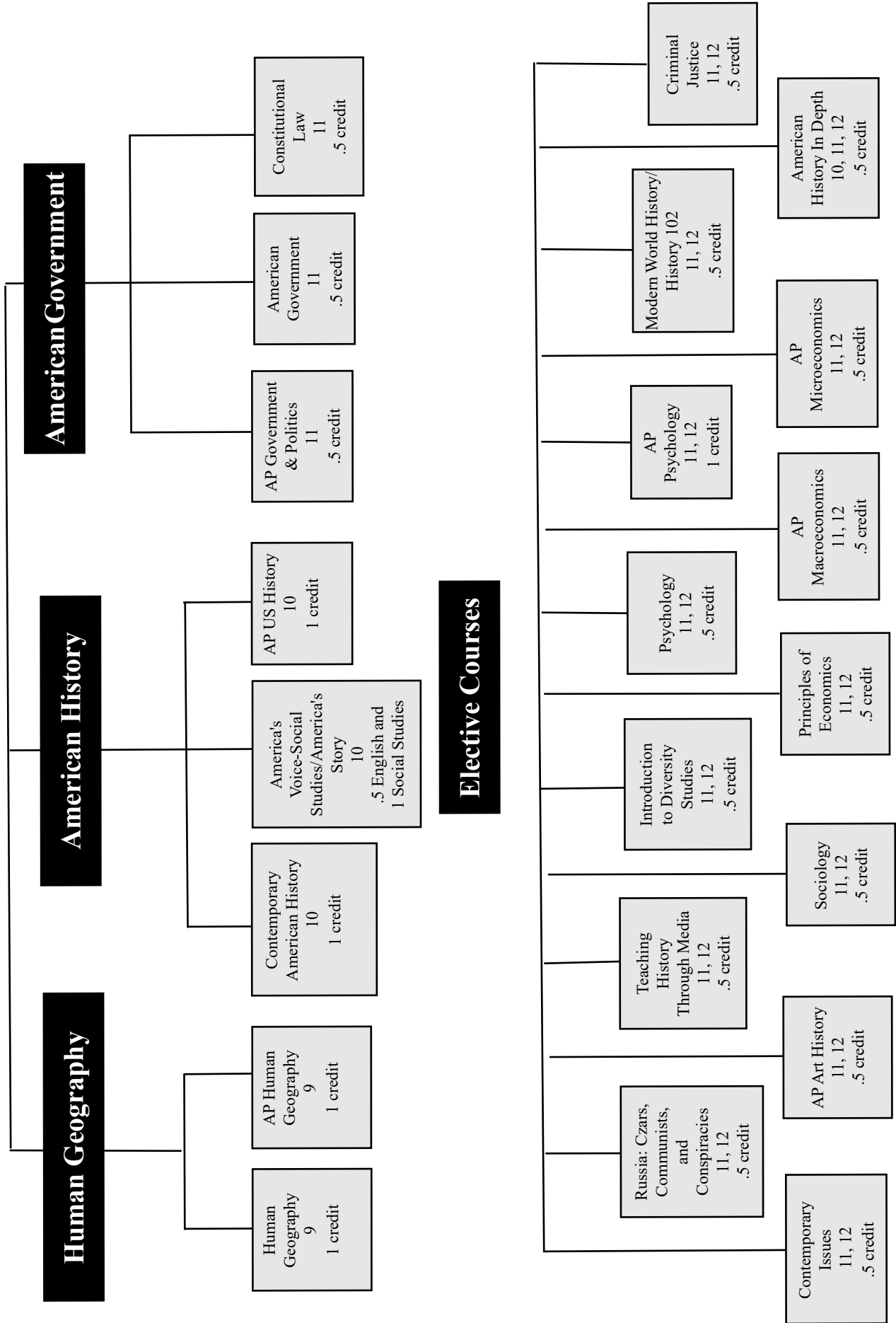

SPECIAL EDUCATION

Special Education assists students in acquiring new skills and learning coping or compensation mechanisms for those they lack. A focus is placed on teaching to specific individual needs and supporting the regular classroom curriculum in an effort to assist each student in achieving his or her potential. In order to enroll in courses offered through the Special Education Department, a student must be referred to a team of educators which will determine eligibility for placement. The Special Education department offers opportunities for assistance in the areas of social/emotional behavior and academics. The Behavior Intervention Center (BIC) helps students manage emotional situations and behaviors in a safe, instructional environment. The Learning Resource Center (LRC) provides a quiet study area with study strategy skills and tutorial assistance.

ID (Intellectual Disabilities)

Functional level courses in English, Science, Health, Mathematics and Social Studies are taught on a rotating semester basis. All courses are interrelated and deal with "Persisting Life Need" themes including: Communications, Understanding One's Life, Health/Safety, Use of Leisure Time, Responsible Citizenship, Earning a Living, Managing Money, Homemaking, Appreciating and Enjoying Fine Arts and Environment.

EBD (Emotional and Behavioral Disabilities)

The primary focus of courses offered through the EBD program is to provide direct instruction on topics dealing with self-concept and social skills. In all EBD classes, students will be expected to participate in community experience activities.

SLD (Specific Learning Disabilities)

Courses offered through specific learning disabilities programs provide the learner with skills necessary to function both in mainstream classes and in independent living. The course offerings include English, Math, Social Studies, and Science. Permission from the instructor is required.

ENGLISH 9

Course: 0101
Credit: 1.0
Grade: 9
Prerequisite: Consent of Special Education Instructor
Fee: None

This English course is designed for freshman students who require course modifications to achieve success. Students will be developing their reading, writing, speaking, listening and vocabulary skills. This course will include poetry, elements of short stories, classical literature, vocabulary and grammar. The curriculum follows the same themes as English I.



ENGLISH 10

Course: 0102
Credit: 1.0
Grade: 10
Prerequisite: Consent of Special Education Instructor
Fee: None

This English course is designed for sophomore students who require course modifications to achieve success. Students will be developing their reading, writing, speaking, listening, and vocabulary skills. Units of study may include poetry, short stories, novels, classical literature, computer research applications, components of literature, writing, and real-life language arts application. The curriculum follows the same themes as English II.



ENGLISH 11

Course: 0103
Credit: 1.0
Grade: 11
Prerequisite: Consent of Special Education Instructor
Fee: None

This English course is designed for junior students who require course modifications to achieve success. Students will be developing their reading, writing, speaking, listening, and vocabulary skills. Units of study include short stories, novels, nonfiction, components of literature, and real life language arts applications. The curriculum follows the same themes as English III.



ENGLISH 12

Course: 0104
Credit: 1.0
Grade: 12
Prerequisite: Consent of Special Education Instructor.
Fee: None

This English course is designed for senior students who require course modifications to achieve success. Students will strengthen reading, writing, speaking, listening and vocabulary skills. Units may include classical literature, real world writing, discussion, novel study, utilizing digital resources and preparing for life after high school.



SPECIAL EDUCATION

READING CONNECTIONS

Course: 0107
Credit: 1.0
Grade: 9, 10, 11, 12
Prerequisite: Consent of Special Education Instructor
Fee: None

Students in this section of English will concentrate on improving their reading comprehension. The course focuses on comprehension skills and strategies with support from vocabulary, fluency, writing, and independent reading. This course is designed for students who have basic phonics and decoding skills but lack solid comprehension and critical thinking skills.

REAL WORLD READING 1

Course: 04.11
Credit: 1.0
Grade: 9, 10
Prerequisite: Consent of Special Education Instructor
Fee: None

Reading is an important part of our everyday lives. Students in this course will develop reading and vocabulary skills they will encounter in everyday life as well as focus on reading for leisure. Lessons will incorporate learning decoding, comprehension, sequencing skills and vocabulary development. Students will also be engaged in novel studies. (Consent of ID staff and current reading levels to determine placement.)

REAL WORLD READING 2

Course: 04.12
Credit: 1.0
Grade: 10, 11, 12
Prerequisite: Consent of Special Education Instructor
Fee: None

This course will continue to focus on reading and vocabulary skills students encounter in their everyday lives as well as focus on reading for leisure. Lessons will incorporate learning decoding, comprehension, sequencing skills and vocabulary development. Students will be engaged in novel studies as well as learn about real world reading and writing such as writing letters, business correspondence, and email etiquette. (Consent of ID staff and current reading levels to determine placement.)

MATH FOR CONSUMERS 1

Course: 0402
Credit: 1.0
Grade: 9, 10, 11, 12
Prerequisite: Consent of Special Education Instructor
Fee: None

This course is designed to give students practice with applying math skills in everyday situations. Topics will include decimals, fractions, percents, earning money, managing money, measuring, and consumer purchasing in real-world applications. Also, the students will begin to learn basic algebraic skills. This will include solving one and two-step equations with variables, as well as working with inequalities.

MATH FOR CONSUMERS 2

Course: 0403
Credit: 1.0
Grade: 9, 10, 11, 12
Prerequisite: Consent of Special Education Instructor
Fee: None

This course builds upon the principles learned in Math for Consumers 1. An emphasis is placed on how math skills are used in real-life situations. Career-related activities are an integral part of the simulation used to represent situations students may encounter after high school. Topics that are covered include: taxes, finding and maintaining a house/apartment, buying and maintaining a car, and travel. Furthermore, the students will build upon their algebraic skills. These skills will include multi-step equations with variables, absolute value equations, and multi-step inequalities.

FUNDAMENTALS OF ALGEBRA

Course: 0404
Credit: 1.0
Grade: 9, 10, 11, 12
Prerequisite: Consent of Special Education Instructor
Fee: None

This class begins with a thorough review of number sense and operations using integers, fractions and decimals. Students are then exposed to selected topics from the Algebra 1 curriculum, emphasizing the solving and graphing of linear equations and systems of equations, along with exposure to exponents, square roots, and perfect squares. The overall goal of this course is to ensure student mastery of the previous topics while preparing the student for future success in Algebra 1 or Fundamentals of Geometry.

FUNDAMENTALS OF GEOMETRY

Course: 0405
Credit: 1.0
Grade: 9, 10, 11, 12
Prerequisite: Consent of Special Education Instructor
Fee: None

Fundamentals of Geometry begins with a thorough review of Algebra skills and number sense. Students are exposed to selected topics from the Geometry curriculum. The student will connect Geometry to Algebra, and explore data analysis, probability, and trigonometry. The overall goal of this course is to ensure student mastery of the previous topics while preparing the student for future success in Geometry.

SPECIAL EDUCATION

MATH 1

Course: 04.42
Credit: 1.0
Grade: 9, 10, 11, 12
Prerequisite: Consent of Special Education Instructor
Fee: None

This mathematics course is designed for students who require course modifications to achieve success. Students will learn number and quantity concepts through the practice of measurement, money and basic number operations. Students will begin to solve simple algebraic expressions. Mathematical concepts will be applied to daily life situations.

MATH 2

Course: 04.43
Credit: 1.0
Grade: 9, 10, 11, 12
Prerequisite: Consent of Special Education Instructor.
Fee: None

This mathematics course is designed for students who require course modifications to achieve success. Students will learn to interpret and build mathematical functions. Students will interpret statistics and probability to make decisions and apply their knowledge to real life scenarios. Specific focus will be placed on money handling skills such as making change and calculating expenses. Topics related to payroll, budgeting, and banking will also be discussed.

WORLD GEOGRAPHY

Course: 0205
Credit: 1.0
Grade: 9, 10
Prerequisite: Consent of Special Education Instructor
Fee: None

World Geography will be a modified curriculum that focuses on topics such as the five themes of geography, world population, resource scarcity, world religions, ethnic constructs and specific aspects of folk and popular culture. Students will gain a basic understanding of the forces shaping our current world. The course will also explore the development of different countries by examining the specific political, economic, cultural, and social aspects that make them all unique.



RESPONSIBLE CITIZENSHIP

Course: 0210
Credit: 1.0
Grade: 10, 11, 12
Prerequisite: Consent of Special Education Instructor
Fee: None

This course will cover topics related to becoming a responsible adult, such as current events and their relationship with historical events and legal rights and responsibilities. In addition, adult independent living skills including self-advocacy, and responsible use of social media will be covered.



HUMAN RELATIONS

Course: 0203 (M), 0202 (F)
Credit: 1.0
Grade: 9, 10
Prerequisite: Consent of Special Education Instructor
Fee: None

The purpose of Human Relations is to develop good social and communication skills needed to be successful in a variety of settings including home, school, social, and work environments. Topics will include character and team-building, communication skills, anger management, resiliency, relationships, and personal commitments.

CHARACTER, LEADERSHIP & LIFE SKILLS

Course: 0204
Credit: .5
Grade: 9, 10, 11, 12
Prerequisite: Consent of Special Education Instructor
Fee: None

This course is designed to teach strategies to strengthen character and build leadership skills needed in a variety of real-life situations. Students will develop skills in self-advocacy, conflict resolution, study strategies, coping strategies; communication, and executive functioning.

HEALTH TOPICS

Course: 04.81
Credit: .5
Grade: 9, 10, 11, 12
Prerequisite: Consent of Special Education Instructor
Fee: None

Health Topics is designed for students who need course modifications to achieve success. Students will explore topics related to eating healthy, lifelong fitness, alcohol, tobacco and drug use and abuse, along with diseases and conditions.

SPECIAL EDUCATION

GENERAL SCIENCE 1

Course: 04.31
Credit: 1.0
Grade: 9, 10
Prerequisite: Consent of Special Education Instructor
Fee: None

General Science I is designed for students who need course modifications to achieve success. Students will explore topics related to Earth and Space Science and Physics. Through hands-on activities, students will explore these science topics and practice application of skills.

GENERAL SCIENCE 2

Course: 04.32
Credit: 1.0
Grade: 10, 11
Prerequisite: Consent of Special Education Instructor
Fee: None

General Science II is designed for students who need course modifications to achieve success. Students will explore topics related to science process, matter, and energy. Through hands-on activities, students will explore these science topics and practice application of skills.

COMMUNITY SCIENCE

Course: 04.34
Credit: 1.0
Grade: 11, 12
Prerequisite: Consent of Special Education Instructor
Fee: None

Community Science is designed for students who need course modifications to achieve success in science. Knowledge from previous science courses will be applied to our community. Topics of exploration include ecosystems in Wisconsin, natural resources in our area, and individual impact on the environment. Students will also become informed of careers related to science in the community.

HEALTH SCIENCE

Course: 04.82(F), 04.83 (M)
Credit: .5
Grade: 9, 10, 11, 12
Prerequisite: Consent of Special Education Instructor
Fee: None

Health Science is designed for students who need course modifications to achieve success. Students will explore topics related to interpersonal relationships such as relationships, dating, sexuality, reproduction systems, STDs, and birth control.

RAPIDS INDIVIDUAL EDUCATION (RIE)

Course: 040 Human Relations
 042 Resource
Credit: Dependant on courses chosen
Grade: 10, 11, 12
Prerequisite: Consent of Special Education Instructor
Fee: None

This program is designed to build and create relationships that will lead to a student's desire to make positive changes in his/her thinking, which in turn, will lead to positive changes in his/her lifestyle. The positive changes will increase the student's motivation and ability to excel in academics, as well as, maintain healthy social and interpersonal relationships throughout their lives. The program includes the following components: a credit recovery component which will enable students to earn academic credit required for graduation, health and fitness, and a behavioral change component. A separate resource period may also be assigned to provide a guided study opportunity, including assistance with organization, study skills, and behavior supports. This resource is not awarded credit.

PHYSICAL EDUCATION

Course: 899
Credit: 1.0
Grade: 9,10, 11, 12
Prerequisite: Consent of Special Education Instructor
Fee: None

Physical Education is a physical education class that has specially designed instruction to meet the unique needs of students with special education needs. Instruction will focus on the development of physical and motor fitness. Skills in aquatics and individual and group games and sports will also be covered.

INDEPENDENT LIVING IN THE DIGITAL AGE

Course: 04.68
Credit: 1.0
Grade: 9, 10
Prerequisite: Consent of Special Education Instructor
Fee: None

This course is designed for students who need course modifications to achieve success. Students are given the opportunity to increase social skills, improve relationships, explore career options, and practice independent living skills. Students will also learn basic computer applications, digital citizenship, and computer literacy. **This course will fulfill the IT Fundamentals 1 graduation requirement.**

SPECIAL EDUCATION

INDEPENDENT LIVING II

Course: 04.69
Credit: 1.0
Grade: 11, 12
Prerequisite: Consent of Special Education Instructor
Fee: None

This course is designed for students who require independent living skills. Units will include places/jobs in the community, transportation, signs and safety, Wisconsin information, laws, laundry and cleaning.

THE WORK PROGRAM: .5, 1.0, or 1.5 Credit Elective - Grades 10, 11, 12

Work experience and good work references are praised by employers and improve individual's chances of getting and keeping a job. These programs provide opportunities to explore careers, to develop and enhance work skills, positive work habits, attitudes, and develop a work reference.

ENGLISH WORK PREP

Course: 04.13
Credit: 1.0
Grade: 11, 12
Prerequisite: Work Study
Fee: None

Through this course students will improve their reading skills by reading job descriptions and identifying skills needed for various job positions. Written communication will be taught through completing job applications, volunteer applications, and resumes. Students will increase their interpersonal communication skills through class discussions and on the job experiences. Students will go to a community job site for a two hour block.

SOCIAL STUDIES WORK PREP

Course: 04.23
Credit: 1.0
Grade: 11, 12
Prerequisite: Work Study
Fee: None

Students will complete team building activities to increase their interpersonal skills. Through a community job site placement, student will incorporate soft skills learned in the classroom to the community environment. Students will go to a community job site for a two hour block.

WORK PREP AND YOUR FINANCES

Course: 04.97
Credit: 1.0
Grade: 11, 12
Prerequisite: Work Study
Fee: None

Students will incorporate verbal and written communication skills learned throughout the year into a community job site placement. Students will develop a strong work ethic in a community job site for a two hour block. During weekly classroom instruction, students will learn and apply financial literacy skills including money management, employment topics, and how education relates to income. **This course will fulfill the financial literacy graduation requirement.**

WORK STUDY

Course: 04.24, 04.25, 04.26
Credit: .5, 1.0, 1.5
Grade: 9, 10, 11, 12
Prerequisite: None
Fee: None

This course is designed to teach the student the transferable work skills. The course investigates career options. The students will learn to appropriately handle an evaluation and practice interviewing skills. These skills are incorporated within work projects which include working in the LHS Coffee Shop.

WORK EXPERIENCE

Course: 04.91, 04.92, 04.93
Credit: .5, 1.0, 1.5
Grade: 10, 11, 12
Prerequisite: None
Fee: None

Work experience is a continuation of the work program which is designed to further develop soft work skills. The student will be working in the community in a position independently obtained. Progress and evaluation of the student will be monitored by LHS staff, and work hours will be documented by students. 65 hours are equivalent to 1/2 credit. 130 hours are equivalent to 1 credit. (Students may be allowed to leave the last period of the day with the consent of the instructor.)

TECHNOLOGY EDUCATION



Courses Required For Graduation From This Department: None

Notice - Safety glasses will not be furnished by the school and must be purchased by the student. If the glasses or goggles are purchased outside of school, they must meet the standards of THE AMERICAN NATIONAL STANDARD PRACTICE FOR OCCUPATIONAL AND EDUCATIONAL EYE AND FACE PROTECTION Z87.1-1968 and subsequent revisions.

Program Offering: Youth Apprenticeships

Auto Technician * STEM * Manufacturing * See page 8 for program details.

COMMUNICATIONS

INTRODUCTION TO GRAPHIC PRODUCTION

Course: 775
Credit: .5
Grade: 9, 10, 11, 12
Prerequisite: None
Fee: \$25.00

Embark on a hands-on graphic design journey using Adobe Illustrator in this dynamic high school course. Beyond digital creation, explore the exciting realm of practical application with tools like a vinyl cutter, laser engraver, and inkjet printer. From vinyl window graphics to personalized t-shirts and more, discover the diverse possibilities of working with vinyl media. This course promises an engaging experience, preparing you for real-world applications in the graphics field. Please note, students are responsible for material costs beyond the \$25.00 course fee. Unleash your creativity and bring your designs to life!

Students will also be responsible for the cost of materials beyond the \$25.00 course fee.

ADVANCED GRAPHIC PRODUCTION

Course: 776
Credit: .5
Grade: 10, 11, 12
Prerequisite: Grade of C or better in Intro. to Graphic Production
Fee: \$25.00

This course is all hands like the intro course. We will be making bigger and more advanced things then move on to seeing how we can impact the school or places in the community to design and create for others as if we are running a small business. Additionally we will research and test other methods that are currently being utilized in industry.

Students will also be responsible for the cost of materials beyond the \$25.00 course fee.

GENERAL ELECTRICITY

Course: 720
Credit: .5
Grade: 9, 10, 11, 12
Prerequisite: None
Fee: \$15.00

This lab/project-oriented class is designed to provide students with a general knowledge of and to develop skills in the following areas: basic electrical circuits, 12-volt automobile wiring, car audio systems, residential house wiring, home electrical systems, alternative energy sources, and small electronic repair. Students will complete a variety of projects within the AC & DC environments.

Safety glasses or goggles are required.

ADVANCED ELECTRICITY

Course: 723.5
Credit: .5
Grade: 10, 11, 12
Prerequisite: General Electricity
Fee: \$15.00

This upper level electronics class will further develop skills that were learned in General Electricity. The main units of focus will be building circuits, developing projects, circuit engineering, design and manufacturing, AC theory, DC theory and basic digital electronics. Students can expect to utilize hands-on projects to further develop their electronic trouble shooting skills.

Students enrolled in this LHS course have the opportunity to register with Mid-State Technical College to receive Dual Credit. See pages 12-13 for details.

Safety glasses or goggles are required.

TECHNOLOGY EDUCATION

CONSTRUCTION

INTRO TO WOODS PROCESSING

Course: 759
Credit: .5
Grade: 9, 10, 11, 12
Prerequisite: None
Fee: \$35.00

This is a lab based course providing students introductory knowledge related to wood processes and machine safety. Students will be constructing multiple small projects during this class.

Safety glasses or goggles are required.

WOODS I

Course: 760
Credit: .5
Grade: 10, 11, 12
Prerequisite: None
Fee: \$75.00

This course is designed to give students hands-on experience in the safe and proper use of common woodworking tools and machines. Students will study units on measurement, planning, design, construction techniques, finish preparation, and finishing. Students will complete a project selected by the instructor. Projects of the student's choice will be allowed upon completion of the required project.

Students will also be responsible for the cost of materials beyond the \$75.00 course fee.

Safety glasses or goggles are required.

WOODS II

Course: 762
Credit: .5
Grade: 11, 12
Prerequisite: C or better in Woodworking I
Fee: \$15.00

Woodworking II will expand on the knowledge and skills gained in Woodworking I. Design and planning for project construction will be a major area of study. Emphases will be placed on machine set-up, advanced machining skills, and safe work practices. Door and drawer construction will be incorporated into student projects. Mass production in woodworking will also be studied.

Students will also be responsible for the cost of materials beyond the \$15.00 course fee.

Safety glasses or goggles are required.

WOODS III

Course: 763
Credit: .5
Grade: 11, 12
Prerequisite: C or better in Woodworking II
Fee: \$15.00

Woods III will allow students to improve on their knowledge in the woodworking area. They will have the opportunity to construct a project of choice utilizing advanced equipment such as the laser engraver and CNC router. Machine safety and set-up will be stressed during this course.

Students will also be responsible for the cost of materials beyond the \$15.00 course fee.

Safety glasses or goggles are required.

BUILDING CONSTRUCTION

Course: 767.5
Credit: 2.5
Grade: 11, 12
Prerequisite: None
Fee: Students will need to purchase their own hand tools and tool belt.

This upper-level hands-on course will give the student an opportunity to construct a residential home from the foundation to the finish work. This course will meet 2 periods during the first term, 1 period during the second term, and 2 periods during the third term. Students will be required to travel daily to the building site. This class is designed for students who wish to gain knowledge related to the construction industry. Students will develop carpentry skills by using current technology and practices in the construction of a wood frame house. This program has a strong tradition of excellence and is a true partnership between the schools and many local businesses. It is our goal to provide students with real work experiences that help them develop skills, knowledge and attitudes that will last a lifetime.

Students will provide their own transportation to and from the building site and provide proof of vehicle insurance.

Time outside the scheduled school day is required.

Students wishing to be considered for this class must meet the following Criteria:

1. Be in good academic standing.
2. Have good attendance and discipline records.
3. Be able to work independently with others.

Students enrolled in this LHS course have the opportunity to register with Mid-State Technical College to receive Dual Credit. See pages 12-13 for details.



TECHNOLOGY EDUCATION

MANUFACTURING

INTRO TO METALS

Course: 750
Credit: .5
Grade: 9, 10, 11, 12
Prerequisite: None
Fee: \$20.00

This course will provide students with an introduction to the metals/manufacturing field through hands-on activities. The student will be completing projects and activities utilizing sheet metal equipment, a metal lathe, welding equipment, a CNC plasma table, and a CNC mill. The projects may include a sheet metal dustpan, a center punch, and CNC ornaments.

Safety glasses or goggles are required.

AMERICAN INDUSTRIES

Course: 758
Credit: .5
Grade: 11, 12
Prerequisite: See course description
Fee: None

American Industries is a class that provides students an opportunity to be an entrepreneur. Students will be able to use equipment such as the laser engraver, CNC plasma cutter, and vinyl cutter to design, market, and create products. These products will be marketed, sold and produced by students. Students will invest in the company and can profit from their hard work and dedication. **Students must take any two classes from the technology education, marketing OR business departments prior to taking American Industries.**

WELDING TECHNOLOGY I

Course: 753.5
Credit: .5
Grade: 10, 11, 12
Prerequisite: None
Fee: \$20.00

Welding Technology I is a hands-on introduction to the welding industry. The course is designed to allow the student the opportunity to explore and apply current industrial welding procedures. Shielded Metal-Arc (stick), Gas Metal-Arc (MIG), Gas Tungsten-Arc (TIG), and Oxyacetylene (gas) welding methods will be explored. Flame cutting, plasma-arc cutting, career opportunities, and other technical areas will be covered. All work will be done on mild steel in the flat position.

Safety glasses or goggles and appropriate leather footwear are required.

Student enrolled in this LHS course have the opportunity to register with Mid-State Technical College to receive Dual Credit. See page 12-13 for details.



WELDING TECHNOLOGY II

Course: 754.5
Credit: 1.0
Grade: 10, 11, 12
Prerequisite: C or better in Welding Technology I
Fee: \$40.00

Welding Technology II is an in-depth exploration of the present day welding and metal fabrication industries. The course is designed to allow the students to improve in both welding knowledge and welding skills. This course requires a great deal of self-direction and responsibility on the part of the student. SMAW, GMAW, GTAW, flux core arc welding, and torch brazing will be performed in various welding positions on both ferrous and nonferrous metals. Oxyfuel and plasma arc cutting skills will be further developed. Students will have the option of completing individual or group projects upon completion of the required lab activities. Related manufacturing techniques, career opportunities, and other technical areas will be explored.

Safety glasses, gauntlet gloves, and appropriate leather footwear are required.

Students enrolled in this LHS course have the opportunity to register with Mid-State Technical College to receive Dual Credit. See page 12-13 for details.



WELDING TECHNOLOGY III

Course: 755
Credit: 1.0
Grade: 11, 12
Prerequisite: C or better in Welding Technology II
Fee: \$30.00

Welding Technology III is an extension of Welding Technology II. The course requires a great deal of self-direction and responsibility on the part of the student. In addition to continuing to explore the present day welding and metal fabrication industries, the student will be required to complete a research project related to the welding/metal fabrication industry. The student has the option to complete lab activities or a project(s) to further improve their welding skills. SMAW, GMAW, GTAW, flux core arc welding, and torch brazing will be performed in various welding positions on both ferrous and nonferrous metals. Oxyfuel and plasma arc cutting skills will be further developed. Related manufacturing techniques, career opportunities, and other technical areas will be explored.

Safety glasses, gauntlet gloves, and appropriate leather footwear are required.

TECHNOLOGY EDUCATION

MANUFACTURING

Course: 748.5
Credit: .5
Grade: 10, 11, 12
Prerequisite: None
Fee: \$20.00

Students will have the opportunity to learn the proper use of metalworking hand tools, lathes, drill presses, power saws, disc grinder, and milling machines. The course will also provide instruction in the use of measuring tools, layout equipment, metal polishing materials, as well as cutting speeds and feeds for material and machines used. Grinding tool bits for all machine applications will be covered and time will be spent on heat treatment of metals. An introduction to CNC machining will be incorporated in the manual machining activity. Career opportunities and other technical areas will be investigated.



Safety glasses or goggles are required.

Students enrolled in this LHS course have the opportunity to register with Mid-State Technical College to receive Dual Credit. See page 12-13 for details.

ADVANCED MANUFACTURING

Course: 749
Credit: .5
Grade: 11, 12
Prerequisite: Manufacturing, CADD, or Welding II
Fee: \$20.00

Advanced Manufacturing is an extension of Manufacturing. The student has the option to focus on CNC machining or manual machining. In the CNC option, the student will learn basic CAM language, use a mill simulator to pre-run CNC programs, use a probing system, load tooling, fixture parts, and run programs to produce parts. The culminating experience will be taking a hands-on test to earn Haas certification as a CNC mill operator. In the manual machining option, the student may operate a lathe, vertical and horizontal milling machines, a surface grinder, a drill press, and other equipment and tools to complete projects. Career opportunities and other technical areas will be explored.

Safety glasses or goggles are required.

TRANSPORTATION

AUTO & HOME MAINTENANCE

Course: 751
Credit: .5
Grade: 11, 12
Prerequisite: None
Fee: \$25.00

This, very basic, course will inform students about common automotive and home maintenance techniques. Students will be able to complete routine automotive, small engine, and home maintenance/repairs. The purpose of this course is to help students obtain knowledge of vehicle and home ownership. This includes the buying process, insurance, basic maintenance and repair regarding each. **Safety glasses or goggles are required to be worn at all times during lab.**

Auto & Home Maintenance is a course designed to provide an offering to juniors and seniors who fall into the category of "nontraditional tech ed" students. A nontraditional tech ed student is a student who has taken no more than one Technology Education course in the manufacturing, woods, or electronics area and hasn't taken any courses in the automotive area and is not currently enrolled in an automotive course.

AVIATION

Course: 773
Credit: .5
Grade: 10, 11, 12
Prerequisite: None
Fee: \$15.00

Aviation gives the student a basic understanding and knowledge of flying and unmanned aircraft systems. Aviation is a student-activity centered course to learn about concepts that have made today's aviation and aerospace possible. Students will construct and work with model airplanes, forces of flight, and flight simulators. **This is NOT an F.F.A. course for obtaining progress towards a pilot's license.**

SMALL ENGINE TECHNOLOGY

Course: 703
Credit: .5
Grade: 9, 10, 11, 12
Prerequisite: None
Fee: \$20.00

Small Engine Technology is an introductory course designed for students interested in small engine technology and possibly the automotive industry. This course will provide students with essential knowledge related to engine theory, design, and operation. Throughout this course students will complete coursework and hands-on lab activities related to small engine technology. Students will thoroughly disassemble, test, repair, and re-assemble a small engine during this course. The school will provide an engine throughout the learning process with students having the opportunity to bring in their own engine upon completion of the school provided engine. Students will be responsible for part/repair costs done on their own engine.

Safety glasses or goggles are required to be worn at all time during lab.

TECHNOLOGY EDUCATION

AUTO SERVICES (Auto 1)

Course: 702
Credit: .5
Grade: 10, 11, 12
Prerequisite: None
Fee: \$20.00

This course is designed for the student that plans to own or drive an automobile. Introducing the many systems associated with vehicle and vehicle maintenance will be the focus of the course. Students will complete coursework and hand-on lab activities related to automotive maintenance. Auto students will need a vehicle to work on at least one day per week. The students will also have to pay for their own maintenance/repair parts.

Safety glasses or goggles are required to be worn at all times during lab.

Student should have a valid driver's license and proof of vehicle insurance.

AUTOMOTIVE SYSTEMS AND REPAIR (Auto 2)

Course: 704
Credit: .5
Grade: 11, 12
Prerequisite: C or better in Auto Services
Fee: \$25.00

This course will provide students with an in-depth understanding of brakes, steering, and suspension systems along with associated repairs. The student will complete lab and classroom activities related to a variety of automotive areas. This course will also start introducing electrical and multimeters. Auto students will need a vehicle to work on at least one day per week. The students will also have to pay for their own maintenance/repair parts.

Students must have a valid driver's license and provide proof of vehicle insurance.

Safety glasses or goggles are required to be worn at all times during lab.

AUTOMOTIVE DIAGNOSTICS (Auto 3)

Course: 705
Credit: .5
Grade: 11, 12
Prerequisite: C or better in Auto Systems and Repair or teacher approval
Fee: \$25.00

This lab based course is devoted to those students interested in a career in the automotive industry or those who want to expand their knowledge and skills in this highly technical field. The student will complete coursework and hands-on lab activities to broaden their knowledge of the different automotive systems through diagnostic practices. Auto students will need a vehicle to work on at least one day per week. The students will also have to pay for their own maintenance/repair parts.

Students must have a valid driver's license and provide proof of vehicle insurance.

Suggested helpful courses include General & Advanced Electricity, Welding I and Manufacturing.

Safety glasses or goggles are required to be worn at all times during lab.

ADVANCED AUTOMOTIVE (Auto 4)

Course: 706
Credit: .5
Grade: 11, 12
Prerequisite: C or better in Automotive Diagnostics or teacher approval
Fee: \$30.00

This lab focused course is devoted to those students interested in a career in the automotive industry or those who want to expand their knowledge and skills in this highly technical field. The student will complete lab and classroom activities related to automotive systems. Auto students will need a vehicle to work on at least one day per week. The students will also have to pay for their own maintenance/repair parts.

Students must have a valid driver's license and proof of vehicle insurance.

Suggested helpful courses include General Electricity, Welding I and Manufacturing.

Safety glasses or goggles are required to be worn at all times during lab.

TECHNOLOGY EDUCATION

ENGINEERING

COMPUTER AIDED DRAWING AND DRAFTING

Course: 711.5
Credit: .5
Grade: 9, 10, 11, 12
Prerequisite: None
Fee: \$10.00

This course will utilize Autodesk Fusion360 software to generate 2-D and 3-D drawings and components of basic parts. Students will develop skills needed to produce working drawings like those used in industry to produce products. Students will be introduced to the operation of a CNC mill by machining a ruler and a keychain. Students will learn to create CAM files in Fusion360. The culminating activity is for the student to draw, generate CAM files, and machine their own part on the CNC mill. No previous computer experience is necessary to succeed in CADD.

Sophomores, Juniors, and Seniors enrolled in this LHS course have the opportunity to register with Mid-State Technical College to receive Dual Credit. See pages 12-13 for details.



Project Lead the Way (PLTW) Engineering students adopt a problem-solving mindset, are engaged in compelling, real-world challenges that help them become better collaborators and thinkers, and are prepared with skills to step into any career path they take.

DIGITAL ELECTRONICS

Course: 726
Credit: 1.0
Grade: 10, 11, 12
Prerequisite: General Electricity or IED
Fee: \$15.00

From smart phones to appliances, digital circuits are all around us. This course provides a foundation for students who are interested in electrical engineering, electronics, or circuit design. Students study topics such as combinational and sequential logic and are exposed to circuit design tools used in industry, including logic gates, integrated circuits, and programmable logic devices.

Recommended Courses: Algebra, Physics

This is a math equivalency course. Successful completion will count toward a third or fourth credit of math. See pages 14 for details.

EC

INTRODUCTION TO ENGINEERING DESIGN

Course: 728
Credit: 1.0
Grade: 9, 10, 11, 12
Prerequisite: None
Fee: \$20.00

Students dig deep into the engineering design process, applying math, science, and engineering standards to hands-on projects. They work both individually and in teams to design solutions to a variety of problems using 3D modeling software, and use an engineering notebook to document their work. Students at Lincoln will prototype designs using a 3D Printer

PRINCIPLES OF ENGINEERING

Course: 730
Credit: 1.0
Grade: 10, 11, 12
Prerequisite: CAD or IED recommended
Fee: \$20.00

Through problems that engage and challenge, students explore a broad range of engineering topics, including mechanisms, the strength of structures and materials, and automation. Students develop skills in problem solving, research, and design while learning strategies for design process documentation, collaboration, and presentation.

Students at Lincoln will also engage in various robot competitions using VEX robotics and a 3D Printer

This is a science equivalency course. Successful completion will count toward a third or fourth credit of science. See pages 14 for details.

EC

ENGINEERING DESIGN AND DEVELOPMENT

Course: 735
Credit: 1.0
Grade: 11, 12
Prerequisite: Two out of the three previous PLTW courses or Instructor approval
Fee: \$20.00

The knowledge and skills students acquire throughout PLTW Engineering come together in EDD as they identify an issue and then research, design, and test a solution, ultimately presenting their solution to a panel of engineers. Students apply the professional skills they have developed to document a design process to standards, completing EDD ready to take on any post-secondary program or career. Students at Lincoln will go through the process of prototyping and creating a patent for their product.

Technology and Engineering

TECHNOLOGY EDUCATION

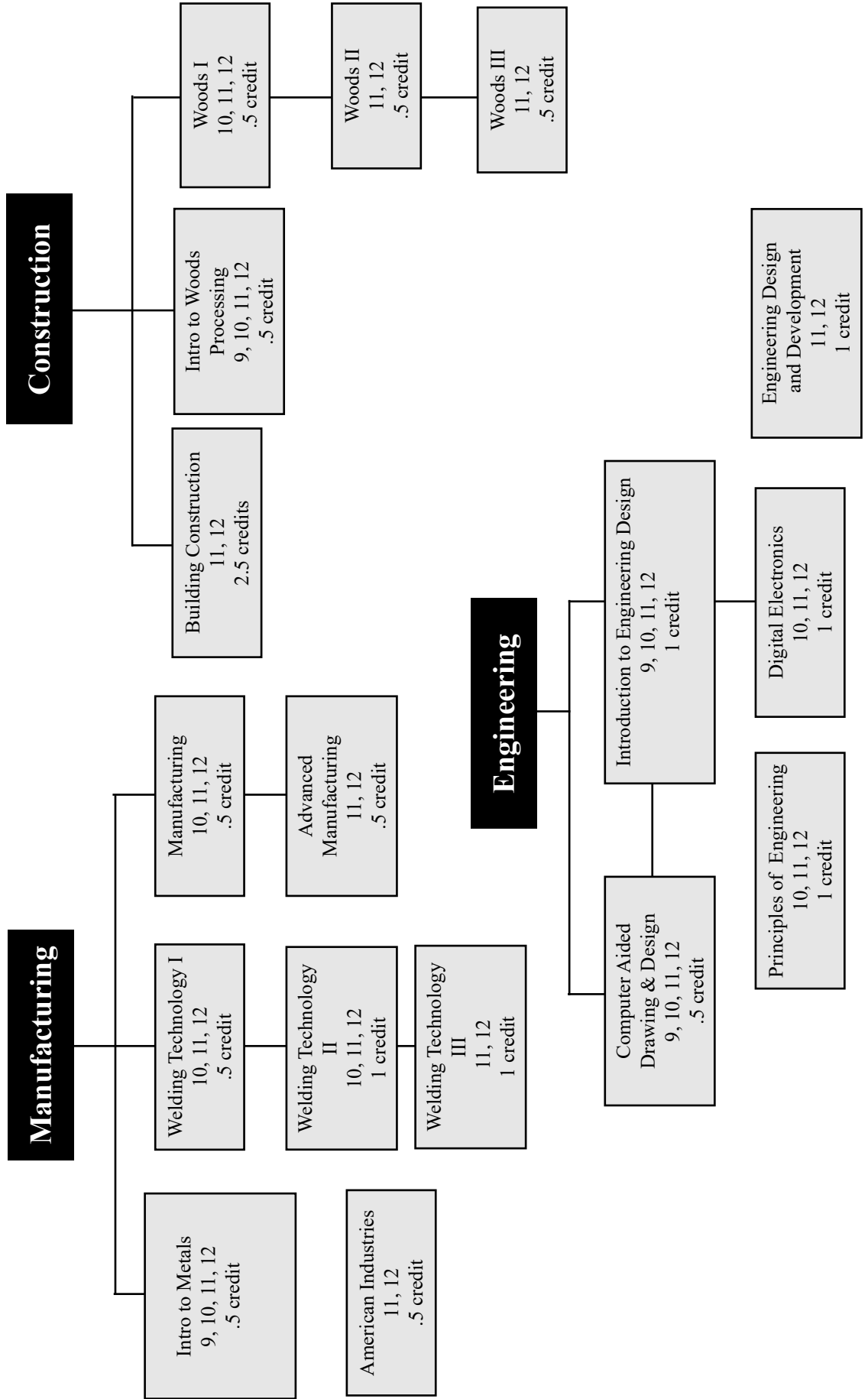

Technology and Engineering

TECHNOLOGY EDUCATION

Communication

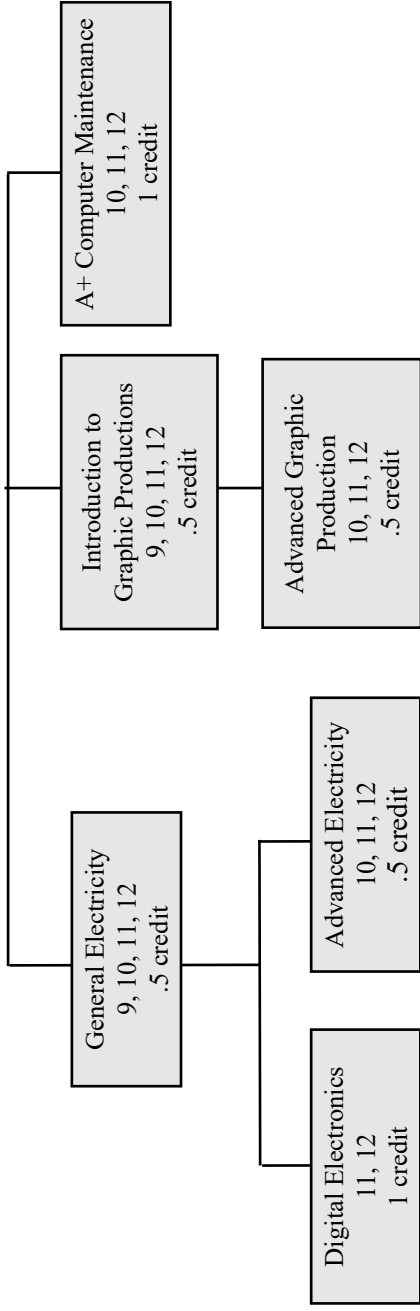

Transportation

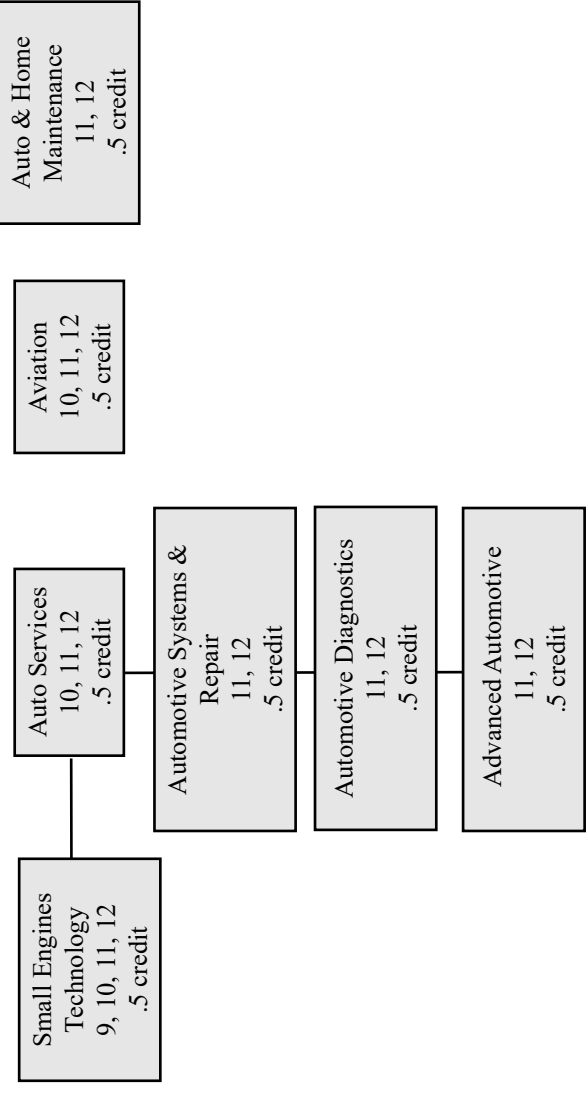

WORLD LANGUAGES



Courses Required For Graduation From This Department: None

What can students study to enhance their chances for just about any career? The answer: STUDY A WORLD LANGUAGE! The U.S. Government and many American businesses are linked to almost every country in the world. Employment opportunities may be greatly enhanced with language skills, especially with four or more years of learning a second language in high school.

Colleges and universities vary in their entrance and exit requirements for students; some have entrance requirements, and others may have exit requirements. The University of Madison, for example, requires at least 2 years of sequential years of language study for admission, but competitive applicants have at least 3 or 4 years (<https://languages.wisc.edu>). Students are advised to contact the Admission's Office of any colleges or universities under consideration and inquire about the availability of retroactive credits for world language study, in addition to entrance and/or graduation requirements specific to that university, program, and/or degree.

For the UW-Wisconsin System, an incoming college freshman can earn a maximum of four semesters of retroactive credits (up to 16 credits, depending upon the university). A placement test determines in which level of foreign language the student is placed. If the student earns a B or better in that class, retroactive credits are awarded. These credits count towards the 120 credits needed for graduation.

If a student has been out of class for a year or more between levels of study (i.e. Level I and Level II), it will be left to the discretion of the teacher whether that student is able to re-enter the program based on an interview. It is recommended that native speakers of any given language, who have never had formal education in that language, be placed in a Level III class until evaluated by his or her teacher.

Our language classes are designed for native English-speaking students. They are not meant for foreign exchange students who speak that particular language as a native language.

LEVEL I

Course: French 800
German 820
Spanish 840

Credit: 1.0

Grade: 9, 10, 11, 12

Prerequisite: None

Fee: \$4.00

This course is for beginning language students. Speaking and listening in the target language will be emphasized. Reading and writing skills are developed on a limited basis. Culture is integrated throughout each unit of study. In this level students will begin to develop proficiencies enabling them to talk about topics such as self, family, the city, leisure time activities, likes/dislikes, sports, food, the weather, and the geography of the countries where the language is spoken. Students gain computer experience in the target language.



LEVEL II

Course: French 803
German 823
Spanish 843

Credit: 1.0

Grade: 9, 10, 11, 12

Prerequisite: Successful completion of Level I (C- or higher in 2nd term of level I.)

Fee: \$4.00

Emphasis continues to be on the development of speaking and listening skills in conjunction with reading and writing. **Lessons are conducted in the target language.** Students will be able to describe activities and interests in greater detail. **Speaking the language is stressed,** talking about topics such as family, clothing, shopping, pastimes, personal care, daily activities, school, jobs and food. Students begin to develop writing fundamentals. Students read both non-fictional texts and some authentic materials. Students complete projects using technology and media.



LEVEL III

Course: French 806
German 826
Spanish 846

Credit: 1.0

Grade: 10, 11, 12

Prerequisite: Successful completion of Level II (C- or higher in 2nd term of level II.)

Fee: None

At this level students continue to develop broader reading and writing skills. **The emphasis remains on speaking and listening. Lessons are conducted in the target language.** Better command of language structures is developed enabling students to express different viewpoints, deal with situations of a more complicated nature, prepare paragraphs such as a resume, character sketches and letters, write in a journal, react and respond to various situations. Students complete projects using technology and media.



WORLD LANGUAGES

LEVEL IV

Course: French 810
 German 830
 Spanish 850

Credit: 1.0

Grade: 11, 12

Prerequisite: Successful completion of Level III (C- or higher in 2nd term of level III.)

Fee: None

This level of language instruction offers further opportunities to develop proficiency in all skills. Lessons are conducted in the target language. More in-depth work with the culture of the countries where the language is spoken will continue through the study of short stories, fine arts, and history. Opportunities are given to demonstrate proficiency in all four skills through dialogues, more complex situations, writings, songs, and daily use of the language. Students complete projects using technology and media.

Seniors enrolled in a level IV or V language class not planning to study at a UW System school (see previous page) may choose to take their respective AP Language exam in May. Doing so will require a student's independent preparation and commitment.



LEVEL V

Course: French 816
 German 836
 Spanish 856

Credit: 1.0

Grade: 12

Prerequisite: Successful completion of Level IV (C- or higher in 2nd term of level IV.)

Fee: None

(Note: French IV and V, and German IV and V follow a two-year alternating curriculum. Although there is no repeat of subject materials during the two years, there is a spiraling of structural concepts and of essential vocabulary.) Emphasis remains on speaking and understanding the target language in more advanced conversations. Students make a variety of formal and informal presentations as they continue to improve and expand upon their speaking skills. Emphasis on writing is accomplished in a variety of contexts. Structural concepts previously studied are enhanced through review and additional materials. Reading comprehension is further developed through short stories, poetry and other authentic literary selections. Internet websites, films and music are used to teach a wide range of cultural aspects.

Seniors enrolled in a level IV or V language class not planning to study at a UW System school (see previous page) may choose to take their respective AP Language exam in May. Doing so will require a student's independent preparation and commitment.



Opportunities for summer travel abroad exist for LHS world language students, every other year, at the student's expense. Please see your world language teacher if you have any questions!



Become a Global Scholar!



Employers and universities are looking for students who are “globally literate.” The Wisconsin Department of Public Instruction has created a new opportunity for students called the Global Education Achievement Certificate.

To earn this distinction, students must complete the following 4 requirements during their four years of high school (grades 9-12):

<p>Coursework: (courses in the Program of Studies that count for this program have this symbol)</p> <ul style="list-style-type: none"> 4 credits (years) of the same World Language 4 credits in courses with a strong global dimension 	<p>Extra-Curricular Activities:</p> <ul style="list-style-type: none"> 4 unique experiences
<p>Books/Art/Music:</p> <ul style="list-style-type: none"> 4 books with international/cultural perspective 4 films/music/art exhibitions 	<p>Community Service:</p> <ul style="list-style-type: none"> 1 global public service project involving at least 20 hours of service

For further information, contact the World Languages Teachers, or go to <http://www.globalwisconsin.org/#!/the-policy/clmxb>. By earning the Global Education Achievement Certificate, students will:

- Earn a “Global Scholar” designation on their transcript.
- Receive a special seal on their diploma.



It is your responsibility to know if your student is NCAA eligible. If you have questions, please contact your student's school counselor OR visit the NCAA Eligibility Website.

www.eligibilitycenter.org

Important Notice:

Nontraditional courses, such as online or virtual courses, may count as core courses for NCAA eligibility. However, it is very important that the STUDENT check with the entity or program providing the instruction to see if the course they are taking meets NCAA Clearinghouse eligibility.

Summer school courses taken through Lincoln High School DO NOT count toward NCAA eligibility.

Not all Lincoln High School core courses count for NCAA credit.

If you have any questions or concerns about NCAA course eligibility, please consult the Lincoln High School website or see your school counselor.

Division I Academic Standards

Division I schools require you to meet academic standards. To be eligible to practice, compete and receive an athletics scholarship in your first year of full-time enrollment, you must meet the following requirements:



1. Earn 16 NCAA-approved core-course credits in the following areas:

<p>ENGLISH</p>	<p>MATH (Algebra I or higher)</p>	<p>SCIENCE (Including one year of lab, if offered)</p>	<p>EXTRA (English, math or science)</p>	<p>SOCIAL SCIENCE</p>	<p>OTHER Any area listed to the left or courses listed in additional discipline (world language, comparative religion or philosophy)</p>
4 years	3 years	2 years	1 year	2 years	4 years

- Complete your 16 NCAA-approved core-course credits in eight academic semesters or four consecutive academic years from the start of ninth grade. If you graduate from high school early, you still must meet core-course requirements.
- Complete 10 of your 16 NCAA-approved core-course credits, including seven in English, math or science, before the start of your seventh semester. Once you begin your seventh semester, any course needed to meet the 10/7 requirement cannot be replaced or repeated.
- Earn a minimum 2.3 **core-course GPA**.
- Ask your high school counselor to upload your **final official transcript** with proof of graduation to your Eligibility Center account.

EARLY ACADEMIC QUALIFIER

If you meet **specific criteria** after six semesters of high school, you may be deemed an early academic qualifier for Division I and may practice, compete and receive an athletics scholarship during your first year of full-time enrollment.

QUALIFIER

You may practice, compete and receive an athletics scholarship during your first year of full-time enrollment.

ACADEMIC REDSHIRT

You may practice during your first regular academic term and receive an athletics scholarship during your first year of full-time enrollment but may NOT compete during your first year of full-time enrollment. You must pass either eight quarter or nine semester hours to practice in the next term.

NONQUALIFIER

You will not be able to practice, compete or receive an athletics scholarship during your first year of full-time enrollment.



NCAA

GRADE

9

REGISTER

- » If you haven't yet, **register** for a free Profile Page account at eligibilitycenter.org for information on NCAA initial-eligibility requirements.
- » Use NCAA Research's **interactive map** to help locate NCAA schools you're interested in attending.
- » Find your high school's list of NCAA-approved core courses at eligibilitycenter.org/courselist to ensure you're taking the right courses, and earn the best grades possible!

GRADE

10

PLAN

- » If you're being actively recruited by an NCAA school and have a Profile Page account, **transition** it to the required **certification account**.
- » Monitor the **task list** in your NCAA Eligibility Center account for next steps.
- » At the end of the school year, ask your high school counselor from each school you attend to upload an official transcript to your Eligibility Center account.
- » If you fall behind academically, ask your high school counselor for help finding **approved courses** you can take.

GRADE

11

STUDY

- » Ensure your **sports participation** information is correct in your Eligibility Center account.
- » Check with your high school counselor to make sure you're on track to complete the required number of NCAA-approved **core courses** and graduate on time with your class.
- » Share your **NCAA ID** with NCAA schools recruiting you so each school can place you on its **institutional request list**.
- » At the end of the school year, ask your high school counselor from each school you attend to upload an official transcript to your Eligibility Center account.

GRADE

12

GRADUATE

- » **Request your final amateurism certification** beginning April 1 (fall enrollees) or Oct. 1 (winter/spring enrollees) in your Eligibility Center account at eligibilitycenter.org.
- » Apply and be accepted to the NCAA school you plan to attend.
- » Complete your final NCAA-approved **core courses** as you prepare for graduation.
- » After you graduate, ask your high school counselor to upload your final **official transcript** with proof of graduation to your Eligibility Center account.

How to plan your high school courses to meet the 16 core-course requirement:

$$4 \times 4 = 16$$

9 th GRADE	10 th GRADE	11 th GRADE	12 th GRADE
(2) English (2) Math (2) Science (2) Social Science and/or other	(2) English (2) Math (2) Science (2) Social Science and/or other	(2) English (2) Math (2) Science (2) Social Science and/or other	(2) English (2) Math (2) Science (2) Social Science and/or other
4 CORE COURSES	4 CORE COURSES	4 CORE COURSES	4 CORE COURSES

CONTACT THE NCAA ELIGIBILITY CENTER

U.S. and Canada (except Quebec):
877-262-1492 (toll free), Monday-Friday
9 a.m. to 5 p.m. Eastern time
International (including Quebec):
on.ncaa.com/IntlContact



[@ncaaec](https://twitter.com/ncaaec) [@ncaaec](https://www.facebook.com/ncaaec) [@ncaaec](https://www.instagram.com/ncaaec) [@ncaaec](https://www.youtube.com/ncaaec) [@ncaaec](https://www.tiktok.com/ncaaec) [@playcollegesports](https://www.youtube.com/playcollegesports)

Division II Academic Standards

Division II schools require you to meet academic standards. To be eligible to practice, compete and receive an athletics scholarship in your first year of full-time enrollment, you must meet the following requirements:

NCAA DIVISION II

MAKE IT YOURS

1. Earn 16 NCAA-approved core-course credits in the following areas:

<p>ENGLISH</p>	<p>MATH (Algebra I or higher)</p>	<p>SCIENCE (Including one year of lab, if offered)</p>	<p>EXTRA (English, math or science)</p>	<p>SOCIAL SCIENCE</p>	<p>OTHER Any area listed to the left or courses listed in additional discipline (world language, comparative religion or philosophy)</p>
<p>3 years</p>	<p>2 years</p>	<p>2 years</p>	<p>3 years</p>	<p>2 years</p>	<p>4 years</p>

2. Earn a minimum 2.2 **core-course GPA**.
3. Ask your high school counselor to upload your **final official transcript** with proof of graduation to your Eligibility Center account.

EARLY ACADEMIC QUALIFIER

If you meet **specific criteria** after six semesters of high school, you may be deemed an early academic qualifier for Division II and may practice, compete and receive an athletics scholarship during your first year of full-time enrollment.

QUALIFIER

You may practice, compete and receive an athletics scholarship during your first year of full-time enrollment.

PARTIAL QUALIFIER

You may practice and receive an athletics scholarship but may NOT compete during your first year of full-time enrollment.



NCAA

GRADE

9

REGISTER

- » If you haven't yet, **register** for a free Profile Page account at eligibilitycenter.org for information on NCAA initial-eligibility requirements.
- » Use NCAA Research's [interactive map](#) to help locate NCAA schools you're interested in attending.
- » Find your high school's list of NCAA-approved core courses at eligibilitycenter.org/courselist to ensure you're taking the right courses, and earn the best grades possible!

GRADE

10

PLAN

- » If you're being actively recruited by an NCAA school and have a Profile Page account, **transition** it to the required **certification account**.
- » Monitor the **task list** in your NCAA Eligibility Center account for next steps.
- » At the end of the school year, ask your high school counselor from each school you attend to upload an official transcript to your Eligibility Center account.
- » If you fall behind academically, ask your high school counselor for help finding **approved courses** you can take.

GRADE

11

STUDY

- » Ensure your **sports participation** information is correct in your Eligibility Center account.
- » Check with your high school counselor to make sure you're on track to complete the required number of NCAA-approved **core courses**.
- » Share your **NCAA ID** with NCAA schools recruiting you so each school can place you on its **institutional request list**.
- » At the end of the school year, ask your high school counselor from each school you attend to upload an official transcript to your Eligibility Center account.

GRADE

12

GRADUATE

- » **Request your final amateurism certification** beginning April 1 (fall enrollees) or Oct. 1 (winter/spring enrollees) in your Eligibility Center account at eligibilitycenter.org.
- » Apply and be accepted to the NCAA school you plan to attend.
- » Complete your final NCAA-approved **core courses** as you prepare for graduation.
- » After you graduate, ask your high school counselor to upload your final **official transcript** with proof of graduation to your Eligibility Center account.

How to plan your high school courses to meet the 16 core-course requirement:

4 x 4 = 16

9th GRADE

(1) English
(1) Math
(1) Science
(1) Social Science and/or other

4 CORE COURSES

10th GRADE

(1) English
(1) Math
(1) Science
(1) Social Science and/or other

4 CORE COURSES

11th GRADE

(1) English
(1) Math
(1) Science
(1) Social Science and/or other

4 CORE COURSES

12th GRADE

(1) English
(1) Math
(1) Science
(1) Social Science and/or other

4 CORE COURSES



CONTACT THE NCAA ELIGIBILITY CENTER

U.S. and Canada (except Quebec):
877-262-1492 (toll free), Monday-Friday
9 a.m. to 5 p.m. Eastern time
International (including Quebec):
on.ncaa.com/IntlContact



[@ncaaec](#) [@ncaaec](#) [@ncaaec](#) [@playcollegesports](#)

CO-CURRICULAR ACTIVITIES

Lincoln High School offers a variety of co-curricular activities that allow for student participation beyond the normal school day. These activities allow students additional opportunities to develop their talents in activities beyond the classroom. We encourage all of our students to become involved in the wide range of activities Lincoln has to offer. Studies have indicated that students involved in co-curricular activities tend to have higher grades, better attendance rates, and higher self-esteem than students who do not participate in co-curricular activities.

The following activities and clubs meet throughout the school year. If you have further questions, please contact your counselor.

Student Activities:

Art Club	French Club	Native Youth Leadership	MUSIC:
Art Honor Society	Gaming Club	Power Club	Acapella Choir
Bloodstone	GSA	Principals Student Advisory Committee	Chamber Players
Bucket Bombers	German Club		Chamber Singers
Calligraphy Club	History Club	Ski & Snowboard Society	Jazz Ensemble
Cheer & Stunt	HOSA (Health Occupations)	Skills USA	Mariachi Band
Chess Club	KEY Club	Stage Tech. Academy	Marching Band
Figure Skating	Knitting Club	Student Council	Men's Choir
Cool 2 Be Kind/Interact	Letterwinners		Musical
Curling Club	LHS Live Stream Team	Theatre Department	Pit Orchestra
Dance Team	LHS Theatre Department	Thespian Troupe 525	Pep Band
DECA (An Association of Marketing Students)	Link Crew	Trapp Club	Tri-M Music Honor Society
Educators Rising	Math League	Visual Arts Classic	Fiddle Squad
Esports	Mock Trial	Volunteer Program	Drumline
FCCLA (Family, Career & Community Leaders of America)	Mountain Biking Club	Yearbook (Ahdawagam)	
FFA	Multicultural Club		
Flannel Club	National Art Honor Society		
Floss Club	National French Honor Society		
Forensics	National Honor Society		

Lincoln High School offers an opportunity for students to become involved in a variety of interscholastic athletic activities.

The following activities are described by season:

FALL — Cross Country (Boys & Girls), Football, Golf (Girls), Soccer (Boys), Tennis (Girls), Swimming (Girls), Volleyball (Girls)

WINTER — Basketball (Boys & Girls), Gymnastics, Hockey (Boys & Girls), Swimming (Boys), Wrestling

SPRING — Baseball (Boys), Golf (Boys), Soccer (Girls), Softball (Girls), Track (Boys & Girls), Tennis (Boys), Lacrosse (Coed)

Academic Performance Is Important For All Extra Curricular Activities

All students should continually strive to achieve their full potential in areas of academic performance and school attendance. In order to participate in competitions and public events, each participant/student-athlete must maintain acceptable academic standards. The acceptable academic standard for LHS co-curricular participation is a progress or a report card that contains no more than one grade of an F. This standard of eligibility is expected to be met during the school year at 6 weeks (during trimester 1), 18 weeks (during trimester 2), and 30 weeks (during trimester 3) and at the end of each term. (Please see the WRPS District Co-Curricular Code of Conduct for more specific information.)

SUCCESS CENTER/PRIDE PROGRAM

SUCCESS CENTER TUTOR PROGRAM

Peer tutoring is a long-standing LHS tradition where students volunteer their time to help other students gain a better understanding of a subject and improve their academic performance. No matter what subject your student needs support in, the tutoring program will find a tutor to help. Tutor teams work on homework assignments, reading/writing skills, and study for tests. They meet two or three times a week before school, during study halls or RPT, or after school.

PRIDE PROGRAM

You will see this PRIDE logo in many places at LHS; on posters and walls at LHS, in newsletters, on t-shirts and magnets. This logo represents what we talk to your students about in class, in the hallway, and in LHS student organizations.

A Positive Behavior Support committee exists that was formed to encourage and develop character excellence. Behavior support will be available for those students who struggle with these expectations and a discipline action plan enforced. Students who are making wise behavioral choices will be recognized on a regular basis as well.

We know that parent involvement in all aspects of a child's education is often the key to the overall success of the student. You might be asking, "What can I as a parent or guardian do at home to encourage these positive behaviors in my child?" Quite simply, talk about them as a family. Copy the PRIDE chart which is found at, <https://www.wrps.org/schools/lincoln/priderewardprogram.cfm>, and post it in a visible spot and encourage these expectations at home. Reference the chart when you see your child using positive behaviors and let them know you appreciate their efforts and actions. On the flip side, when you see negative behaviors or attitudes, talk to them about the expectation and ways to make improvements.

Our goal is to create and maintain a safe and effective learning environment ensuring that all students graduating from LHS possess the social and emotional skills necessary for a successful future.

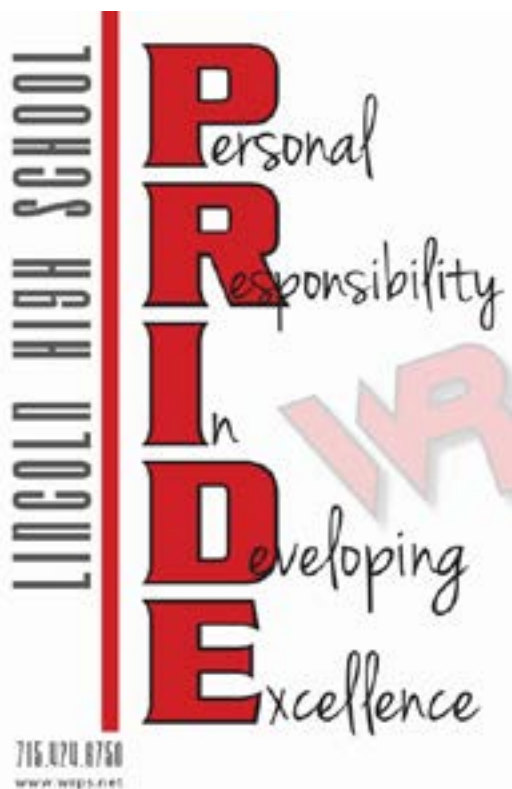

"Working together with home and community, we are dedicated to providing the best education for every student, enabling each to be a thoughtful, responsible contributor to a changing world."

IMPORTANT DATES FOR 2024-2025 SCHOOL YEAR

SCHEDULE PICK UP DAYS

Mark your calendars to attend one of the times listed below to take care of back to school paperwork and pick up your schedule.

WEDNESDAY - AUGUST 21, 2024

11:00 am - 3:00 pm

THURSDAY - AUGUST 22, 2024

1:00 pm - 5:30 pm

WEDNESDAY - AUGUST 28, 2024

3:30 pm - 7:00 pm

LINK CREW ORIENTATION

WEDNESDAY - AUGUST 21, 2024

8:00 am - 12:00 pm

This course is required for all freshmen and will take place on August 21, 2024 for 4 hours starting in the morning. Link Crew is designed to link freshmen with successful upperclassmen with the intention of creating a positive and cohesive school culture. Through the implementation of energetic and purposefully designed activities, students will experience a curriculum rich in team and individual skill development. Students will leave this course more prepared to have a successful high school experience while obtaining skills which promote post-secondary college and career readiness.

**This Program of Studies is current as of the time it goes to print. At times updates to courses and fees are made after the printing of this book. To see the most current information, view the Program of Studies at:
http://www.wrps.org/schools/lincoln/lhs_program_of_studies.cfm.**

FOUR-YEAR ACADEMIC PLANNING GUIDE

		Freshman	Sophomore	Junior	Senior
		Academic Year 20__-20__	Academic Year 20__-20__	Academic Year 20__-20__	Academic Year 20__-20__
	Minimum credits for Graduation				TOTAL
Required					
English	4.0	English I (1 Credit)	English II (1 Credit)		
Social Studies (See the social studies section for grade level requirements.)	3.0				
Math	3.0				
Science	3.0				
Phy. Ed.	1.5	PE I (1/2 Credit)			
Health	0.5				
Financial Literacy	0.5				
IT Fundamentals I	0.5				
SUB TOTAL	16.0				
Electives					
	Minimum of 8.0 Elective Credits for Graduation				

Twenty four (24) credits minimum are required for graduation for Lincoln High School. Sixteen (16) are in specific required areas, the remaining seven (8.0) or more can be from either core or elective areas.

****The Financial Literacy Credit can be satisfied with:**

- Personal Finance - No. 506, Accelerated Financial Algebra- No. 422, Financial Algebra - No. 421, On Your Own - No. 939, Principles of Economics - No. 222, AP Macroeconomics - No.233, or AP Microeconomics- No. 234.

The minimum graduation requirements are not always adequate for admission to the University of Wisconsin and some other four-year universities. For university admission you must complete math courses through Algebra 2. Three credits of science, sometimes specifically in the areas of Biology, Chemistry, and Physics, are required. At least two years of a World Language are recommended by some universities, and required by UW-Madison and many University of Minnesota campuses. Technical college admission for scientific, technical or health programs may also require higher standards. Specific admission requirements vary by campus; see your counselor for more details.